



aerospace
climate control
electromechanical
filtration
fluid & gas handling
hydraulics
pneumatics
process control
sealing & shielding



Stainless Steel Body Air Cylinders

SR/SRM, SRD/SRDM, SRG/SRGM Series

Catalog 0978



ENGINEERING YOUR SUCCESS.

SR/SRD, SRD/SRDM Series

Features, Ordering Information..... 1
 Mounting Styles 2-23
 Air Reservoirs 24
 Accessories 25-26

SRX Series

Features, Ordering Information..... 27
 Dual Set Point Controller..... 28
 Mounting Styles 29-33
 Accessories 34

SRG/SRGM Series

Features, Ordering Information..... 35
 Mounting Styles 36-37
 Accessories 38

Electronic Sensors 39-42

Safety Guide 43

Offer of Sale 44

 WARNING

FAILURE OR IMPROPER SELECTION OR IMPROPER USE OF THE PRODUCTS AND/OR SYSTEMS DESCRIBED HEREIN OR RELATED ITEMS CAN CAUSE DEATH, PERSONAL INJURY AND PROPERTY DAMAGE.

This document and other information from Parker Hannifin Corporation, its subsidiaries and authorized distributors provide product and/or system options for further investigation by users having technical expertise. It is important that you analyze all aspects of your application including consequences of any failure, and review the information concerning the product or system in the current product catalog. Due to the variety of operating conditions and applications for these products or systems, the user, through its own analysis and testing, is solely responsible for making the final selection of the products and systems and assuring that all performance, safety and warning requirements of the application are met.

The products described herein, including without limitation, product features, specifications, designs, availability and pricing, are subject to change by Parker Hannifin Corporation and its subsidiaries at any time without notice.

Offer of Sale

The items described in this document are hereby offered for sale by Parker Hannifin Corporation, its subsidiaries or its authorized distributors. This offer and its acceptance are governed by the provisions stated on the separate page of this document entitled "Offer of Sale".

SR Series

- 304 stainless steel cylinder body, non repairable construction
- Aluminum heads and caps, Delrin heads and caps are optional
- 12 bore sizes — 5/16" through 3" (see dimensional tables for SRM and SRD/SRDM exclusions).
- Stainless steel piston rods are standard up to 1.50" bore
- 28 standard mounting styles (not all available on SRM and SRD/SRDM – see table on following page)
- Single and double acting
- Adjustable cushions optional on both ends



Operating information

Operating pressure: 250 PSIG (17 bar) for SR and SRM
 100 PSIG (7 bar) for SRD/SRDM

Temperature range: -10°F to 165°F (-23°C to 74°C) for SR
 14°F to 140°F (-10°C to 60°C) for SRM
 32°F to 160°F (0°C to 71°C) for SRD/SRDM

Filtration requirements: 40 micron, dry filtered air

Ordering information

1.06	C		D	SR	B	V			C	2.00																																																	
<table border="1" style="width: 100%; border-collapse: collapse;"> <tr><th colspan="2">Bore Size ¹</th></tr> <tr><td>.31</td><td>5/16"</td></tr> <tr><td>.44</td><td>7/16"</td></tr> <tr><td>.56</td><td>9/16"</td></tr> <tr><td>.75</td><td>3/4"</td></tr> <tr><td>.88</td><td>7/8"</td></tr> <tr><td>1.06</td><td>1-1/16"</td></tr> <tr><td>1.25</td><td>1-1/4"</td></tr> <tr><td>1.50</td><td>1-1/2"</td></tr> <tr><td>1.75</td><td>1-3/4"</td></tr> <tr><td>2.00</td><td>2"</td></tr> <tr><td>2.50</td><td>2-1/2"</td></tr> <tr><td>3.00</td><td>3"</td></tr> </table>	Bore Size ¹		.31	5/16"	.44	7/16"	.56	9/16"	.75	3/4"	.88	7/8"	1.06	1-1/16"	1.25	1-1/4"	1.50	1-1/2"	1.75	1-3/4"	2.00	2"	2.50	2-1/2"	3.00	3"	<div style="border: 1px solid black; padding: 2px; margin-bottom: 5px;"> Cushion Head ² Use "C" only when cushion head is required. </div> <div style="border: 1px solid black; padding: 2px; margin-bottom: 5px;"> Double Rod Use "K" only when double rod is required. Available on DX and DXH mounting only. </div> <div style="border: 1px solid black; padding: 2px;"> Mounting ^{1,5} N, NR, NRP, P, R, RP, D, DP, DXP, DX, DXH, A, RA, AP, AR, BRN, BRR, BFD, BRD, BFN, BFR, TRN, TRR, TFD, TRD, TFN or TFR. </div>		<table border="1" style="width: 100%; border-collapse: collapse;"> <tr><th colspan="2">Series</th></tr> <tr><td>SR</td><td>Standard cylinder</td></tr> <tr><td>SRM</td><td>With magnetic piston</td></tr> <tr><td>SRD</td><td>With delrin caps</td></tr> <tr><td>SRDM</td><td>With delrin caps and magnetic piston</td></tr> </table>	Series		SR	Standard cylinder	SRM	With magnetic piston	SRD	With delrin caps	SRDM	With delrin caps and magnetic piston	<table border="1" style="width: 100%; border-collapse: collapse;"> <tr><th colspan="2">Piston</th></tr> <tr><td>Blank</td><td>No bumpers</td></tr> <tr><td>B</td><td>With bumpers ³</td></tr> </table>	Piston		Blank	No bumpers	B	With bumpers ³			<div style="border: 1px solid black; padding: 2px; margin-bottom: 5px;"> Non-Standard Rod Specify Y for stainless steel piston rod. Stainless steel is standard on all bore sizes up to and including 1.50" Bore. </div> <div style="border: 1px solid black; padding: 2px; margin-bottom: 5px;"> Non-Standard Piston Rod Use "3" only when special piston rod end is required. Specify CC, LE and A Dimensions (See next page.) </div> <div style="border: 1px solid black; padding: 2px; margin-bottom: 5px;"> Cushion Cap ² Use "C" only when cushion cap is required. </div>	<table border="1" style="width: 100%; border-collapse: collapse;"> <tr><th colspan="2">Seals</th></tr> <tr><td>Blank</td><td>Standard seals</td></tr> <tr><td>V</td><td>Fluorocarbon seals ⁴</td></tr> <tr><td>W</td><td>Rod wiper</td></tr> </table>	Seals		Blank	Standard seals	V	Fluorocarbon seals ⁴	W	Rod wiper	<div style="border: 1px solid black; padding: 2px; margin-bottom: 5px;"> Special Use "S" only if special modifications are required, except piston rod end. </div> <div style="border: 1px solid black; padding: 2px;"> Stroke Specify in inches. </div>
Bore Size ¹																																																											
.31	5/16"																																																										
.44	7/16"																																																										
.56	9/16"																																																										
.75	3/4"																																																										
.88	7/8"																																																										
1.06	1-1/16"																																																										
1.25	1-1/4"																																																										
1.50	1-1/2"																																																										
1.75	1-3/4"																																																										
2.00	2"																																																										
2.50	2-1/2"																																																										
3.00	3"																																																										
Series																																																											
SR	Standard cylinder																																																										
SRM	With magnetic piston																																																										
SRD	With delrin caps																																																										
SRDM	With delrin caps and magnetic piston																																																										
Piston																																																											
Blank	No bumpers																																																										
B	With bumpers ³																																																										
Seals																																																											
Blank	Standard seals																																																										
V	Fluorocarbon seals ⁴																																																										
W	Rod wiper																																																										
<p>¹ Bore sizes and mounting styles are limited by series. See table on next page for availability.</p> <p>² Cushions not available on SRD/SRDM series or KDX mounts.</p> <p>³ Bumpers may increase cylinder length. Please reference catalog 0900P-E, page D37 for adders.</p> <p>⁴ Fluorocarbon seals not available on SRM or SRDM series.</p> <p>⁵ TRD mount not available with cushions.</p>																																																											

Sensors
 For sensors see page 39-42.

For ordering purposes, when special options or common modifications are requested, the factory will assign a sequential part number in place of the model number.

Non-Standard Rods

For non-standard rod dimensions, or undersized rod end threads, put a "3" in model number and describe the rod using the letters shown in the drawing. Specify CC, LE and A dimensions. LE is measured in retracted position.

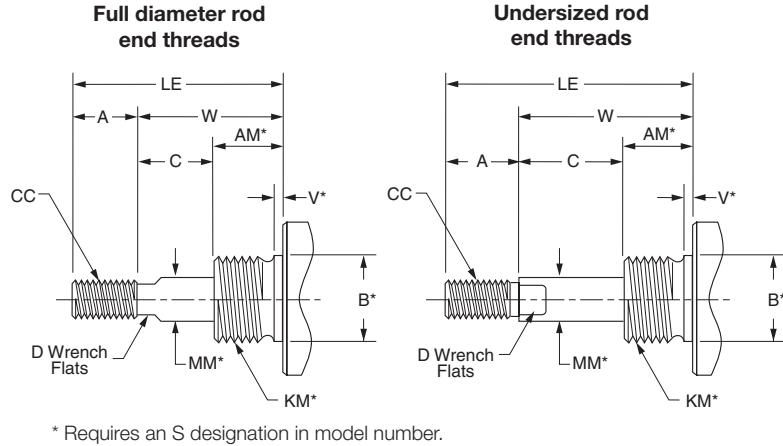

Mounting Style N

Nose mount, spring return

Bore size	SR	SRM	Std. strokes (in)	Max. stroke (in)	SS rod std
5/16"	•		1/2, 1, 1-1/2, 2, 2-1/2, 3, 4	4	✓
7/16"	•		1/2, 1, 1-1/2, 2, 2-1/2, 3, 4	6	✓
9/16"	•	•	1/2, 1, 1-1/2, 2, 3, 4	6	✓
3/4"	•	•	1/2, 1, 1-1/2, 2, 3, 4	6	✓
7/8"	•		1/2, 1, 1-1/2, 2, 3, 4	6	✓
1-1/16"	•	•	1/2, 1, 1-1/2, 2, 3, 4	6	✓
1-1/4"	•	•	1/2, 1, 2, 3, 4	6	✓
1-1/2"	•	•	1/2, 1, 2, 3, 4	6	✓
1-3/4"	•	•	1/2, 1, 1-1/2, 2, 2-1/2, 3, 4	6	
2"	•	•	-	4	

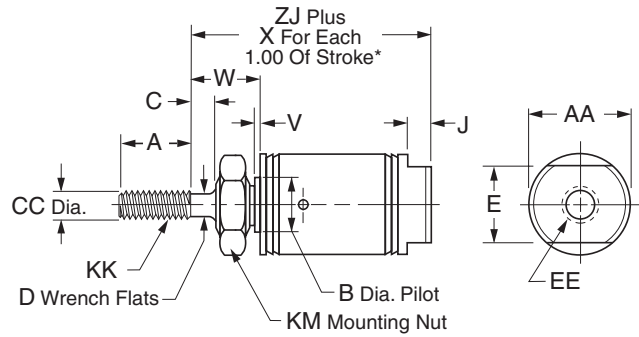

Bore size															ZJ	
	A	AA	B	C	CC	D	E	EE	J	KK	KM	V	W	X	SR	SRM
5/16"	0.38	0.36	-	-	0.125	-	0.36	#10-32	-	#5-40 UNC	1/4-28	0	0.25	0.75**	1.12	-
7/16"	0.50	0.50	0.374	-	0.188	-	0.38	#10-32	0.19	#10-32 UNF	3/8-24	0.05	0.31	0.94**	1.31	-
9/16"	0.50	0.62	0.437	-	0.188	-	0.50	#10-32	0.19	#10-32 UNF	7/16-20	0.06	0.38	1.62	1.53	1.76
3/4"	0.50	0.81	0.499	-	0.250	-	0.62	1/8 NPTF	0.19	1/4-28 UNF	1/2-20	0.09	0.44	1.69	1.50	1.75
7/8"	0.50	0.93	0.624	-	0.250	-	0.62	1/8 NPTF	0.19	1/4-28 UNF	5/8-18	0.09	0.50	1.56	1.84	-
1-1/16"	0.50	1.12	0.624	0.12	0.312	0.25	0.88	1/8 NPTF	0.19	5/16-24 UNF	5/8-18	0.09	0.69	1.56	2.06	2.31
1-1/4"	0.75	1.34	0.749	0.25	0.437	0.38	0.88	1/8 NPTF	0.25	7/16-20 UNF	3/4-16	0.09	0.88	1.81	2.66	2.78
1-1/2"	0.75	1.56	0.749	0.25	0.437	0.38	0.88	1/8 NPTF	0.25	7/16-20 UNF	3/4-16	0.09	0.88	1.69	2.44	2.69
1-3/4"	0.88	1.84	1.031	0.38	0.500	7/16	1.25	1/4 NPTF	0.25	1/2-20 UNF	1-14	0.09	0.75	2.0	2.97	3.09
2"	0.88	2.08	1.374	0.38	0.625	0.50	1.25	1/4 NPTF	0.31	1/2-20 UNF	1-1/4-120.12	1.19	-	▲	▲	

▲ SR: 5.41" for 1" stroke, 7.41" for 2" stroke, 8.66" for 3" stroke, 11.59" for 4" stroke.
 SRM: 5.66" for 1" stroke, 7.66" for 2" stroke, 8.91" for 3" stroke, 11.84" for 4" stroke.

* To determine lengths for half inch stroke increments, determine length for next highest whole number stroke and subtract a half inch.

** For each 0.50" of stroke



Mounting Style NR

Nose mount, spring return, hex rod

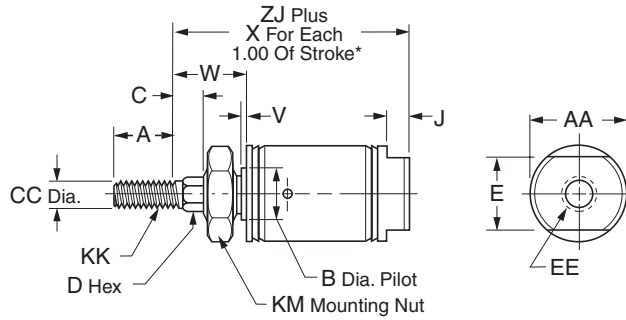

Bore size	SR	SRM	Std. stroke (in)	Max.. stroke (in)	SS rod std
7/16"	•		1/2, 1, 1-1/2, 2, 3, 4	6	✓
9/16"	•	•	1/2, 1, 1-1/2, 2, 3, 4	6	✓
3/4"	•	•	1/2, 1, 1-1/2, 2, 3, 4	6	✓
7/8"	•		1/2, 1, 1-1/2, 2, 3, 4	6	✓
1-1/16"	•	•	1/2, 1, 1-1/2, 2, 3, 4	6	✓
1-1/4"	•	•	1, 2, 3, 4	6	✓
1-1/2"	•	•	1/2, 1, 2, 3, 4	6	✓
1-3/4"	•	•	1/2, 1, 1-1/2, 2, 2-1/2, 3, 4	6	

Bore size	A	AA	B	C	CC	D	E	EE	J	KK	KM	V	W	X	ZJ	
															SR	SRM
7/16"	0.50	-	0.374	0.25	0.188	3/16	-	#10-32	0.19	#10-32 UNF	3/8-24	0.05	0.56	0.94	1.56	-
9/16"	0.50	-	0.437	0.25	0.188	3/16	-	#10-32	0.19	#10-32 UNF	7/16-20	0.06	0.62	1.62	1.78	2.03
3/4"	0.50	-	0.499	0.25	0.250	1/4	-	1/8 NPTF	0.19	1/4-28 UNF	1/2-20	0.09	0.69	1.69	1.75	2.00
7/8"	0.50	-	0.624	0.25	0.250	1/4	-	1/8 NPTF	0.19	1/4-28 UNF	5/8-18	0.09	0.75	1.56	2.09	-
1-1/16"	0.50	1.12	0.624	0.25	0.312	3/8	0.88	1/8 NPTF	0.19	5/16-24 UNF	5/8-18	0.09	0.75	1.56	2.19	2.44
1-1/4"	0.88	1.34	0.749	0.25	0.437	7/16	0.88	1/8 NPTF	0.25	7/16-20 UNF	3/4-16	0.09	0.88	1.81	2.66	2.78
1-1/2"	0.88	1.56	0.749	0.38	0.437	7/16	0.88	1/8 NPTF	0.25	7/16-20 UNF	3/4-16	0.09	1.00	1.69	2.56	2.81
1-3/4"	0.88	1.84	1.031	0.38	0.500	1/2	1.25	1/4 NPTF	0.25	1/2-20 UNF	1-14	0.09	1.12	2.0	3.03	3.15

* To determine lengths for half inch stroke increments, determine length for next highest whole number stroke and subtract one half inch.

Mounting Style NRP

Pivot & nose mount, spring return, hex rod

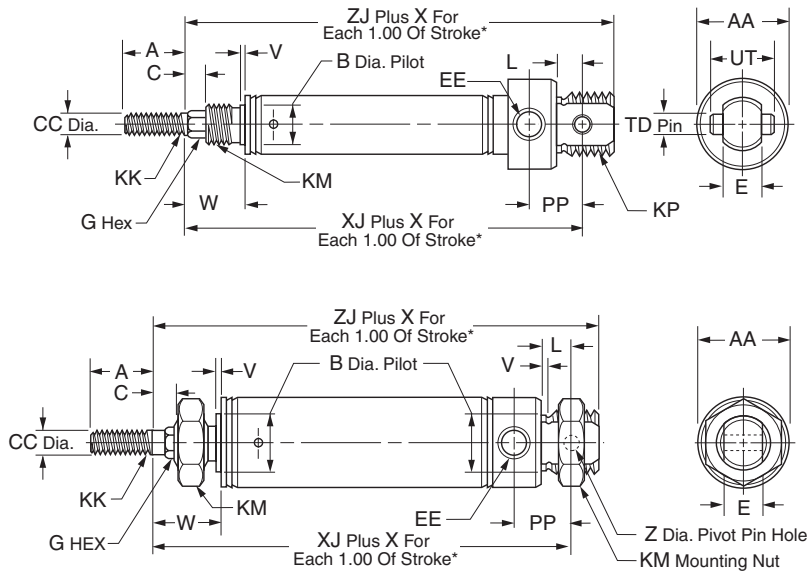

Bore sizes

7/16" *
3/4"

* No mounting nuts

Bore sizes

9/16" *
7/8" *
1-1/16" *
1-1/4"
1-1/2" *
1-3/4"

* No mounting nuts

Bore size	SR	SRM	Std. stroke (in)	Max. stroke (in)	SS rod std	A	AA	B	C	CC	E	EE
7/16"	•		1/2, 1, 1-1/2, 2, 3, 4	6	✓	0.50	0.74	0.374	0.25	0.188	0.31	#10-32
9/16"	•	•	1/2, 1, 1-1/2, 2, 3, 4	6	✓	0.50	0.62	0.437	0.25	0.188	0.31	#10-32
3/4"	•	•	1, 2, 3, 4	6	✓	0.50	0.86	0.499	0.25	0.250	0.38	1/8 NPTF
7/8"	•		1, 2, 3, 4	6	✓	0.50	0.93	0.624	0.25	0.250	0.38	1/8 NPTF
1-1/16"	•	•	1, 2, 3, 4	6	✓	0.50	1.12	0.624	0.25	0.312	0.38	1/8 NPTF
1-1/4"	•	•	1, 2, 3, 4	6	✓	0.88	1.34	0.749	0.25	0.437	0.50	1/8 NPTF
1-1/2"	•	•	1, 2, 3, 4	6	✓	0.88	1.56	0.749	0.38	0.437	0.62	1/8 NPTF
1-3/4"	•	•	1/2, 1, 1-1/2, 2, 2-1/2, 3, 4	6		0.88	1.84	1.031	0.38	0.500	0.62	1/4 NPTF

Bore size	G HEX	KK	KM	KP	L	PP	TD	UT	V	W	X	XJ			ZJ	
												SR	SRM	Z	SR	SRM
7/16"	3/16	#10-32 UNF	3/8-24	7/16-20 UNF	0.25	0.44	0.156	0.50	0.05	0.56	0.94	2.00	-	-	2.25	-
9/16"	3/16	#10-32 UNF	7/16-20	7/16-20 UNF	0.25	0.38	-	-	0.06	0.62	1.62	2.06	2.31	0.157	2.25	2.50
3/4"	1/4	1/4-28 UNF	1/2-20	5/8-18 UNF	0.34	0.62	0.250	0.75	0.09	0.69	1.69	2.53	2.78	-	2.81	3.06
7/8"	1/4	1/4-28 UNF	5/8-18	5/8-18 UNF	0.34	0.62	0.250	0.75	0.09	0.75	1.56	2.72	-	-	3.00	-
1-1/16"	3/8	5/16-24 UNF	5/8-18	5/8-18 UNF	0.34	0.62	0.250	0.75	0.09	0.75	1.56	2.78	3.03	-	3.06	3.31
1-1/4"	7/16	7/16-20 UNF	3/4-16	-	0.41	0.78	0.251	-	0.09	0.88	1.81	3.38	3.50	0.251	3.78	3.91
1-1/2"	7/16	7/16-20 UNF	3/4-16	-	0.50	0.81	0.375	1.00	0.09	1.00	1.69	3.25	3.50	-	3.62	3.87
1-3/4"	1/2	1/2-20 UNF	1-14	-	0.50	1.12	0.376	0.62	0.09	1.12	2.0	4.09	4.21	0.376	4.59	4.71

* To determine lengths for half inch stroke increments, determine length for next highest whole number stroke and subtract one half inch.

Mounting Style P

Pivot mount, spring return

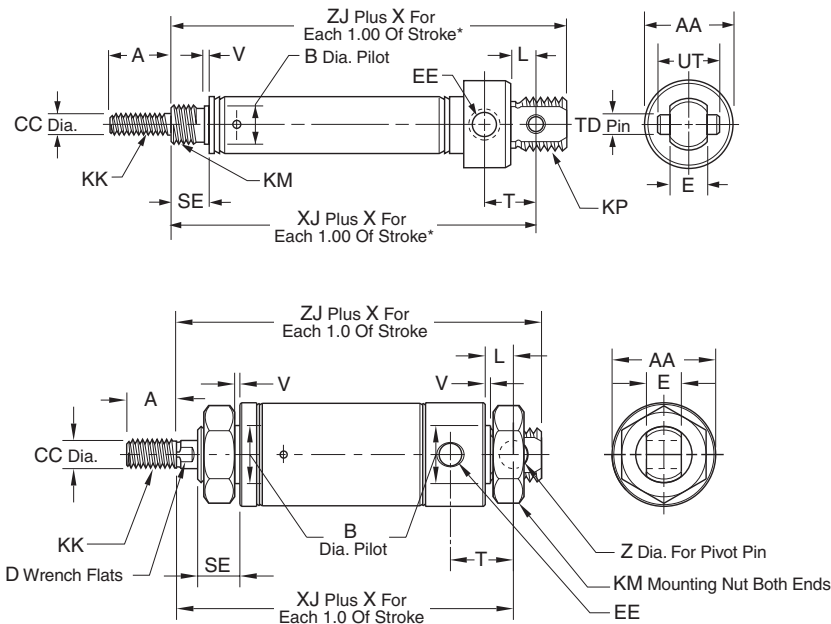

Bore sizes
5/16" *
7/16"
3/4"

* No mounting nuts

Bore sizes
9/16" *
7/8" *
1-1/16" *
1-1/4"
1-1/2" *
1-3/4"
2" *

* No mounting nuts

Bore size	SR	SRM	Std. stroke (in)	Max. stroke (in)	SS rod std	A	AA	B	CC	D	E	EE
5/16"	•		1/2, 1, 1-1/2, 2, 3, 4	4	✓	0.38	0.39	-	0.125	-	0.25	#10-32
7/16"	•		1/2, 1, 1-1/2, 2, 3, 4	6	✓	0.50	0.74	0.374	0.188	-	0.31	#10-32
9/16"	•	•	1/2, 1, 1-1/2, 2, 3, 4	6	✓	0.50	0.62	0.437	0.188	-	0.31	#10-32
3/4"	•	•	1/2, 1, 1-1/2, 2, 3, 4	6	✓	0.50	0.86	0.499	0.250	-	0.38	1/8 NPTF
7/8"	•		1/2, 1, 1-1/2, 2, 3, 4	6	✓	0.50	0.93	0.624	0.250	-	0.38	1/8 NPTF
1-1/16"	•	•	1/2, 1, 1-1/2, 2, 3, 4	6	✓	0.50	1.12	0.624	0.312	0.25	0.38	1/8 NPTF
1-1/4"	•	•	1, 2, 3, 4	6	✓	0.75	1.34	0.749	0.437	0.38	0.50	1/8 NPTF
1-1/2"	•	•	1, 2, 3, 4	6	✓	0.75	1.56	0.749	0.437	0.38	0.62	1/8 NPTF
1-3/4"	•	•	1/2, 1, 1-1/2, 2, 2-1/2, 3, 4	6		0.88	1.84	1.031	0.500	7/16	0.62	1/4 NPTF
2"	•	•	-	4		0.88	2.08	1.374	0.625	0.50	0.75	1/4 NPTF

Bore size	KK	KM	KP	L	SE	T	TD	UT	V	X	XJ		ZJ		
											SR	SRM	Z	SR	SRM
5/16"	#5-40 UNC	3/8-24	-	0.34	0.25	0.34	-	-	-	0.75	1.52	-	0.125	1.68	-
7/16"	#10-32 UNF	3/8-24	7/16-20 UNF	0.25	0.31	0.44	0.156	0.50	0.05	0.94	1.75	-	-	2.00	-
9/16"	#10-32 UNF	7/16-20	7/16-20 UNF	0.25	0.38	0.38	-	-	0.06	1.62	1.81	2.06	0.157	2.00	2.25
3/4"	1/4-28 UNF	1/2-20	5/8-18 UNF	0.34	0.44	0.62	0.250	0.75	0.09	1.69	2.28	2.53	-	2.56	2.81
7/8"	1/4-28 UNF	5/8-18	5/8-18 UNF	0.34	0.50	0.62	0.250	0.75	0.09	1.56	2.47	-	-	2.75	-
1-1/16"	5/16-24 UNF	5/8-18	5/8-18 UNF	0.34	0.50	0.62	0.250	0.75	0.09	1.56	2.66	2.91	-	2.94	3.19
1-1/4"	7/16-20 UNF	3/4-16	-	0.41	0.63	0.78	-	-	0.09	1.81	3.38	3.91	0.251	3.78	3.50
1-1/2"	7/16-20 UNF	3/4-16	-	0.50	0.63	0.81	0.375	1.00	0.09	1.81	3.12	3.37	-	3.50	3.75
1-3/4"	1/2-20 UNF	1-14	-	0.50	0.75	1.12	-	-	0.09	2.0	4.03	4.15	0.376	4.53	4.65
2"	1/2-20 UNF	1-1/4-12	-	0.56	0.81	1.03	-	-	0.12	-	■	*	-	▲	◆

- 6.34" for 1" stroke, 8.34" for 2" stroke, 9.59" for 3" stroke, 12.53" for 4" stroke*
- ▲ 6.78" for 1" stroke, 8.78" for 2" stroke, 10.03" for 3" stroke, 12.97" for 4" stroke*
- * 6.59" for 1" stroke, 8.59" for 2" stroke, 9.84" for 3" stroke, 12.78" for 4" stroke*
- ◆ 7.03" for 1" stroke, 9.03" for 2" stroke, 10.28" for 3" stroke, 13.22" for 4" stroke*

* To determine lengths for half inch stroke increments, determine length for next highest whole number stroke and subtract a half inch.



Parker Pneumatic

Mounting Style R

Nose mount, spring extended

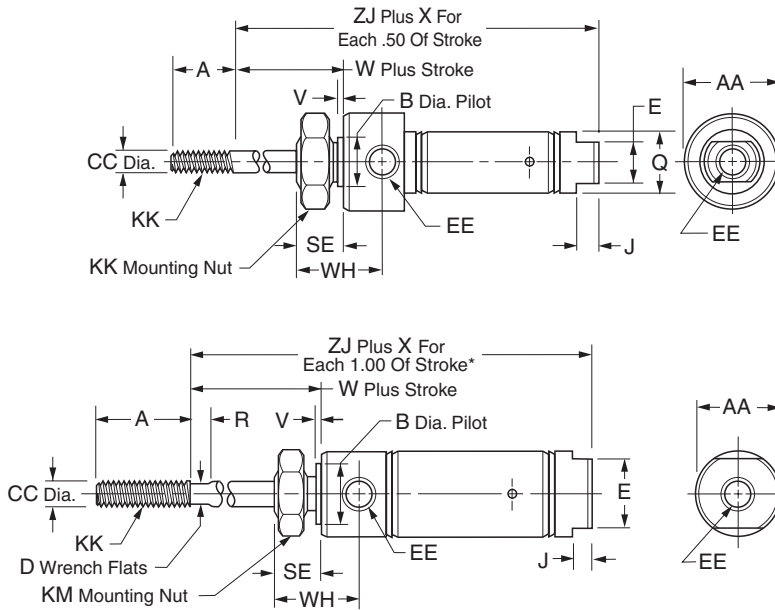

Bore sizes

5/16"
7/16"
3/4"

Bore sizes

9/16"
7/8"
1-1/16"
1-1/4"
1-1/2"
1-3/4"
2" *

* No mounting nuts

Bore size	SR	SRM	Std. stroke (in)	Max. stroke (in)	SS rod std	A	AA	B	CC	D	E
5/16"	•		1/2, 1, 1-1/2, 2, 2-1/2, 3	4	✓	0.38	0.50 SQ.	-	0.125	-	-
7/16"	•		1/2, 1, 1-1/2, 2, 3	6	✓	0.50	0.74	0.437	0.188	-	0.38
9/16"	•	•	1/2, 1, 1-1/2, 2, 3	6	✓	0.50	0.62	0.437	0.188	-	0.50
3/4"	•	•	1/2, 1, 2, 3, 4	6	✓	0.50	0.86	0.624	0.250	-	-
7/8"	•		1/2, 1, 2, 3, 4	6	✓	0.50	0.93	0.624	0.250	-	-
1-1/16"	•	•	1/2, 1, 1-1/2, 2, 3, 4	6	✓	0.50	1.12	0.624	0.312	0.25	-
1-1/4"	•	•	1, 2, 3, 4	6	✓	0.75	1.34	0.749	0.437	0.38	-
1-1/2"	•	•	1, 2, 3, 4	6	✓	1.25	1.56	0.749	0.437	0.38	0.88
1-3/4"	•	•	1/2, 1, 1-1/2, 2, 2-1/2, 3, 4	6		0.88	1.84	1.031	0.500	7/16	-
2"	•	•	-	4		0.88	2.08	1.374	0.625	0.50	-

Bore size												ZJ	
	EE	J	KK	KM	Q	R	SE	V	W	WH	X	SR	SRM
5/16"	#10-32	-	#5-40 UNC	3/8-24	0.36	-	0.31	-	0.31	0.47	1.25	1.49	-
7/16"	#10-32	0.19	#10-32 UNF	7/16-20	0.50	-	0.38	0.05	0.38	0.72	1.44	1.94	-
9/16"	#10-32	0.19	#10-32 UNF	7/16-20	0.62	-	0.38	0.05	0.38	0.78	2.62	2.00	2.25
3/4"	1/8 NPTF	-	1/4-28 UNF	5/8-18	0.81	-	0.50	0.09	0.50	0.97	2.69**	2.31	2.56
7/8"	1/8 NPTF	-	1/4-28 UNF	5/8-18	-	-	0.50	0.09	0.50	0.97	2.56	2.31	-
1-1/16"	1/8 NPTF	-	5/16-24 UNF	5/8-18	-	0.12	0.50	0.09	0.62	1.06	2.81	2.62	2.87
1-1/4"	1/8 NPTF	-	7/16-20 UNF	3/4-16	-	0.25	0.62	0.09	0.88	1.38	2.81	3.47	3.60
1-1/2"	1/8 NPTF	0.25	7/16-20 UNF	3/4-16	-	0.25	0.62	0.09	0.88	1.25	3.00	3.19	3.44
1-3/4"	1/4 NPTF	-	1/2-20 UNF	1-14	-	-	0.75	0.09	1.06	1.63	3.0	4.03	4.15
2"	1/4 NPTF	-	1/2-20 UNF	1-1/4-12	-	0.38	0.81	0.12	1.19	1.47	-	▲	◆

▲ 7.11" for 1" stroke, 10.11" for 2" stroke, 12.34" for 3" stroke, 16.34" for 4" stroke.*

◆ 7.36" for 1" stroke, 10.36" for 2" stroke, 12.59" for 3" stroke, 16.59" for 4" stroke*

* To determine lengths for half inch stroke increments, determine length for next highest whole number stroke and subtract one half inch.

** For each 1.00" of stroke.

Mounting Style RP

Pivot and nose mount, spring extended

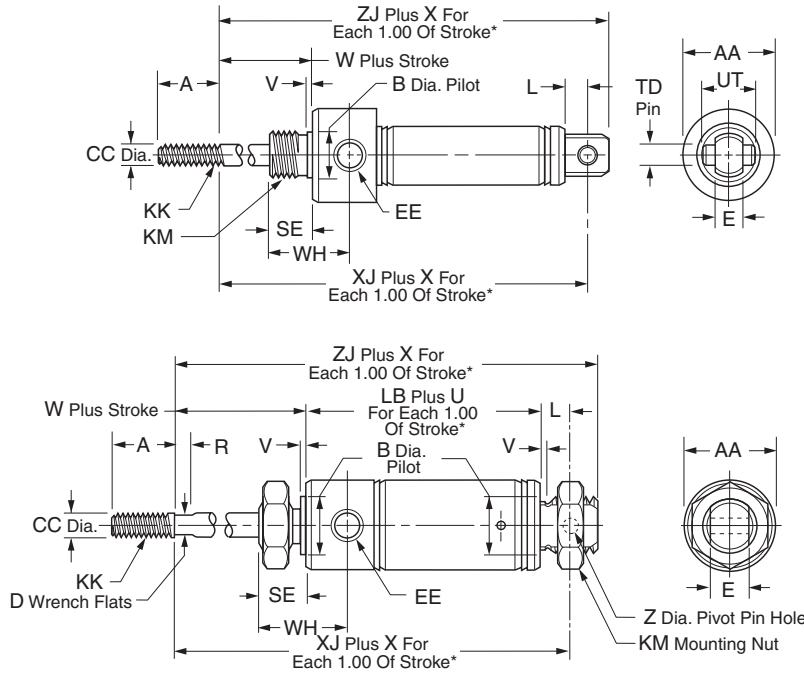

Bore sizes
5/16" *
7/16"
3/4"

* No mounting nuts

Bore sizes
9/16" *
7/8" *
1-1/16" *
1-1/4"
1-1/2" *
1-3/4"
2" *

* No mounting nuts

Bore size	SR	SRM	Std. stroke (in)	Max. stroke (in)	SS rod std	A	AA	B	CC	D	E	EE	KK
5/16"	•		1/2, 1, 1-1/2, 2, 2-1/2, 3	4	✓	0.38	0.50 SQ.	-	0.125	-	0.25	#10-32	#5-40 UNC
7/16"	•		1/2, 1, 1-1/2, 2, 3	6	✓	0.50	0.74	0.437	0.188	-	0.31	#10-32	#10-32 UNF
9/16"	•	•	1/2, 1, 1-1/2, 2, 3	6	✓	0.50	0.62	0.437	0.188	-	0.31	#10-32	#10-32 UNF
3/4"	•	•	1/2, 1, 2, 3, 4	6	✓	0.50	0.86	0.624	0.250	-	0.38	1/8 NPTF	1/4-28 UNF
7/8"	•		1/2, 1, 2, 3, 4	6	✓	0.50	0.93	0.624	0.250	-	0.38	1/8 NPTF	1/4-28 UNF
1-1/16"	•	•	1/2, 1, 1- 1/2, 2, 3, 4	6	✓	0.50	1.12	0.624	0.312	0.25	0.38	1/8 NPTF	5/16-24 UNF
1-1/4"	•	•	1, 2, 3, 4	6	✓	0.75	1.34	0.749	0.437	0.38	0.50	1/8 NPTF	7/16-20 UNF
1-1/2"	•	•	1, 2, 3, 4	6	✓	1.25	1.56	0.749	0.437	0.38	0.62	1/8 NPTF	7/16-20 UNF
2"	•	•	-	4		.88	2.08	1.374	0.625	0.50	0.75	1/4 NPTF	1/2-20 UNF

Bore size	KM	L	LB	R	SE	TD	U	UT	V	W	WH	X	XJ			ZJ	
													SR	SRM	Z	SR	SRM
5/16"	3/8-24	0.19	-	-	0.31	-	-	-	-	0.31	0.47	1.25	1.88	-	-	2.04	-
7/16"	7/16-20	0.25	-	-	0.38	0.156	-	0.50	0.05	0.38	0.72	1.44	2.38	-	-	2.62	-
9/16"	7/16-20	0.25	-	-	0.38	-	-	-	0.06	0.38	0.78	2.62	2.28	2.53	0.157	2.47	2.72
3/4"	5/8-18	0.34	-	-	0.50	0.250	-	0.75	0.09	0.50	0.97	2.69	2.44	2.69	-	2.72	2.97
7/8"	5/8-18	0.34	-	-	0.50	0.250	-	0.75	0.09	0.50	0.97	2.56	2.63	-	-	2.91	-
1-1/16"	5/8-18	0.34	-	0.12	0.50	0.250	-	0.75	0.09	0.62	1.06	2.81	2.78	3.03	-	3.06	3.31
1-1/4"	3/4-16	0.41	2.47	0.25	0.62	-	1.81	-	0.09	0.88	1.38	2.81	3.78	3.91	0.251	4.16	4.28
1-1/2"	3/4-16	0.50	-	0.25	0.62	0.375	-	1.00	0.09	0.88	1.25	3.00	3.88	4.13	-	4.25	4.50
2"	1-1/4 -12	0.56	-	0.38	0.81	-	-	-	0.12	1.19	1.47	-	■	*	0.376	▲	◆

- 8.05" for 1" stroke, 11.05" for 2" stroke, 13.28" for 3" stroke, 17.28" for 4" stroke*
- ▲ 8.50" for 1" stroke, 11.50" for 2" stroke, 13.72" for 3" stroke, 17.72" for 4" stroke*
- * 8.31" for 1" stroke, 11.31" for 2" stroke, 13.53" for 3" stroke, 17.53" for 4" stroke*
- ◆ 8.75" for 1" stroke, 11.75" for 2" stroke, 13.97" for 3" stroke, 17.97" for 4" stroke*

* To determine lengths for half inch stroke increments, determine length for next highest whole number stroke and subtract one half inch.



Mounting Style D

Nose mount, double acting

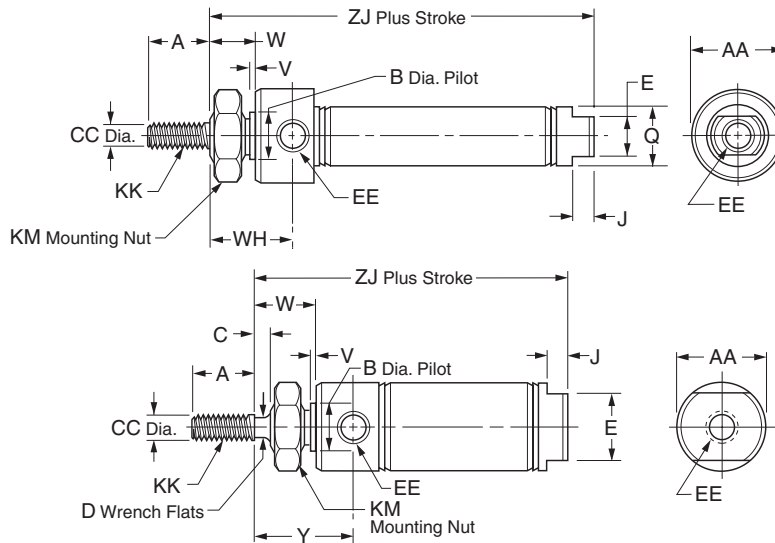

Bore sizes

- 5/16"
- 7/16"
- 3/4"

Bore sizes

- 9/16"
- 7/8"
- 1-1/16"
- 1-1/4"
- 1-1/2"
- 1-3/4"
- 2" *
- 2-1/2" *
- 3" *

* No mounting nuts

Bore size	SR	SRM	SRD SRDM	Std. stroke (in)	Max. stroke (in)	SS rod std	A	AA	B	C	CC
5/16"	•			1/2, 1, 1-1/2, 2, 2-1/2, 3, 4	4	✓	0.38	0.50 SQ.	-	-	0.125
7/16"	•			1/2, 1, 1-1/2, 2, 3, 4	12	✓	0.50	0.74	0.437	-	0.188
9/16"	•	•	•	1/2, 1, 1-1/2, 2, 3, 4	12	✓	0.50	0.62	0.437	-	0.188
3/4"	•	•	•	1/2, 1, 2, 2-1/2, 3, 4, 5, 6, 8, 10	12	✓	0.50	0.86	0.624	-	0.250
7/8"	•			1/2, 1, 2, 3, 4, 5, 6	12	✓	0.50	0.93	0.624	-	0.250
1-1/16"	•	•	•	1/2, 1, 1-1/2, 2, 2-1/2, 3, 4, 5, 6, 8, 10, 12	12	✓	0.50	1.12	0.624	0.12	0.312
1-1/4"	•	•		1, 2, 3, 4, 5, 6	12	✓	0.75	1.34	0.749	0.25	0.437
1-1/2"	•	•	•	1/2, 1, 2, 3, 4, 5, 6, 8, 10, 12	12	✓	0.75	1.56	0.749	0.25	0.437
1-3/4"	•	•		1/2, 1, 1-1/2, 2, 2-1/2, 3, 4, 5, 6	12		0.88	1.84	1.031	0.31	0.500
2"	•	•	•	-	12		0.88	2.08	1.374	0.38	0.625
2-1/2"	•	•		-	12		0.88	2.62	1.500	0.38	0.625
3"	•			-	12		1.25	3.16	1.630	0.38	0.750

Bore size	D	E	EE	J	KK	KM	Q	V	W	WH	Y	ZJ	
												SR	SRM
5/16"	-	-	#10-32	-	#5-40 UNC	3/8-24	0.36	-	0.31	0.47	-	1.64	-
7/16"	-	0.38	#10-32	0.19	#10-32 UNF	7/16-20	0.50	0.05	0.38	0.72	-	2.12	-
9/16"	-	0.50	#10-32	0.19	#10-32 UNF	7/16-20	-	0.06	0.38	0.78	-	2.28	2.53
3/4"	-	0.62	1/8 NPTF	0.19	1/4-28 UNF	5/8-18	0.81	0.09	0.50	0.97	-	2.97	2.97
7/8"	-	0.62	1/8 NPTF	0.19	1/4-28 UNF	5/8-18	-	0.09	0.50	0.97	-	2.94	-
1-1/16"	0.25	0.88	1/8 NPTF	0.19	5/16-24 UNF	5/8-18	-	0.09	0.62	-	1.19	3.25	3.41
1-1/4"	0.38	0.88	1/8 NPTF	0.25	7/16-20 UNF	3/4-16	-	0.09	0.88	-	1.62	4.00	4.03
1-1/2"	0.38	0.88	1/8 NPTF	0.25	7/16-20 UNF	3/4-16	-	0.09	0.88	-	1.50	3.69	3.94
1-3/4"	7/16	1.25	1/4 NPTF	0.25	1/2-20 UNF	1-14	-	0.09	1.06	1.63	-	4.69	4.69
2"	0.50	1.25	1/4 NPTF	0.31	1/2-20 UNF	1-1/4-12	-	0.12	1.19	-	1.84	4.69	4.97
2-1/2"	1/2	1.75	1/4 NPTF	0.31	1/2-20 UNF	1-3/8-12	-	0.13	1.19	-	1.84	4.69	4.69
3"	5/8	2.00	3/8 NPTF	0.31	5/8-18 UNF	1-1/2-12	-	0.19	1.38	-	2.09	5.25	-



Mounting Style DP

Pivot and nose mount, double acting, pivot pin

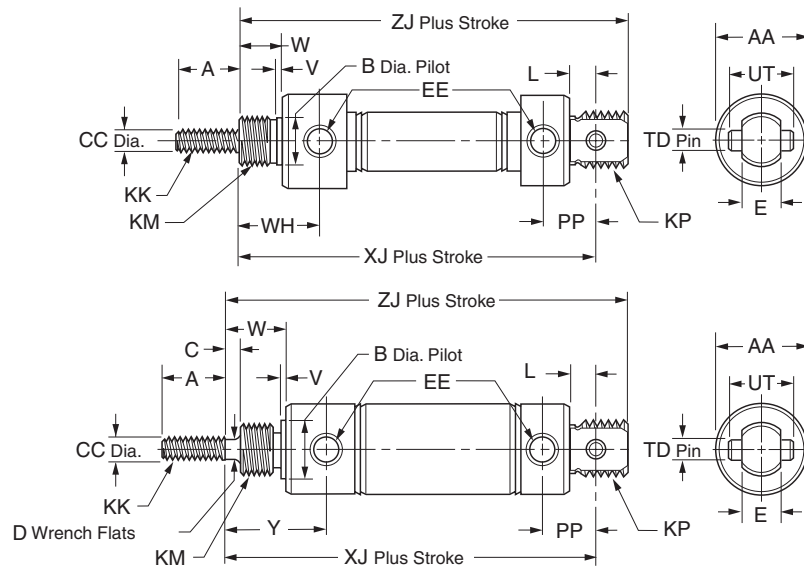

Bore sizes
5/16"
7/16"
3/4"

Bore sizes
1-1/16"
1-1/2"

Bore size	SR	SRM	Std. stroke (in)	Max. stroke (in)	SS rod	A	AA	B	CC	D	E
7/16"	•		1/2, 1, 1-1/2, 2, 3, 4	12	✓	0.50	0.74	0.437	0.188	-	0.31
3/4"	•	•	1/2, 1, 2, 2-1/2, 3, 4, 5, 6, 8, 10	12	✓	0.50	0.86	0.624	0.250	-	0.38
1-1/16"	•	•	1/2, 1, 1-1/2, 2, 2-1/2, 3, 4, 5, 6, 8, 10, 12	12	✓	0.50	1.12	0.624	0.312	0.25	0.38
1-1/2"	•	•	1, 2, 3, 4, 5, 6, 8, 10, 12	12	✓	0.75	1.56	0.749	0.437	0.38	0.62

Bore size	EE	KK	KM	KP	L	PP	TD	UT	V	W	WH	XJ			ZJ	
												SR	SRM	Y	SR	SRM
7/16"	#10-32	#10-32 UNF	7/16-20	7/16-20 UNF	0.25	0.44	0.156	0.50	0.05	0.38	0.72	2.56	-	-	2.81	-
3/4"	1/8 NPTF	1/4-28 UNF	5/8-18	5/8-18 UNF	0.34	0.62	0.250	0.75	0.09	0.50	0.97	3.75	3.75	-	4.03	4.03
1-1/16"	1/8 NPTF	5/16-24 UNF	5/8-18	5/8-18 UNF	0.34	0.62	0.250	0.75	0.09	0.62	-	3.84	4.00	1.19	4.12	4.28
1-1/2"	1/8 NPTF	7/16-20 UNF	3/4-16	-	0.50	0.81	0.375	1.00	0.09	0.87	-	4.38	4.63	1.50	4.75	5.00

Mounting Style DXP

Pivot & nose mount, double acting, no pivot pin

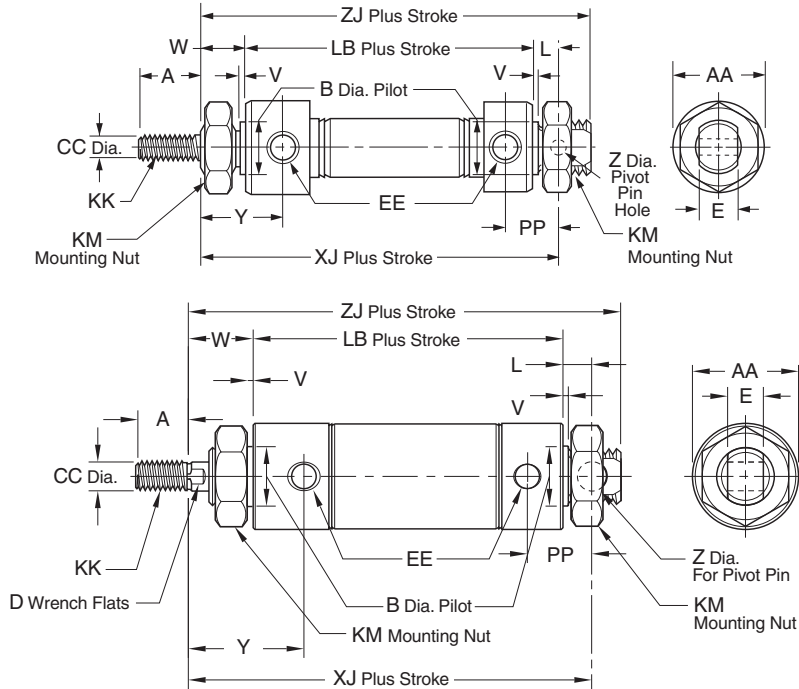

Bore sizes
5/16"
7/16"
3/4"

Bore sizes
9/16" *
7/8"
1-1/16"
1-1/4"
1-1/2"
1-3/4"
2" *
2-1/2" *
3" *

* No mounting nuts

Bore size	SR	SRM	SRD	SRDM	Std. stroke (in)	Max. stroke (in)	SS rod std	A	AA	B	CC	D	E
5/16"	•				1/2, 1, 1-1/2, 2, 2-1/2, 3, 4	4	✓	0.38	0.50 SQ.	-	0.125	-	0.25
7/16"	•				1/2, 1, 1-1/2, 2, 3, 4	12	✓	0.50	0.74	0.437	0.188	-	0.31
9/16"	•	•	•		1/2, 1, 1-1/2, 2, 3, 4	12	✓	0.50	0.62	0.437	0.188	-	0.31
3/4"	•	•	•		1, 2, 3, 4, 5, 6, 8, 10	32	✓	0.50	0.86	0.624	0.250	-	0.38
7/8"	•				1, 2, 3, 4, 5, 6, 8, 10	32	✓	0.50	0.93	0.624	0.250	-	0.38
1-1/16"	•	•	•		1/2, 1, 1-1/2, 2, 2-1/2, 3, 4, 5, 6, 8, 10, 12	32	✓	0.50	1.12	0.624	0.312	0.25	0.38
1-1/4"	•	•			1, 2, 3, 4, 5, 6, 7, 8, 10, 12	32	✓	0.75	1.34	0.749	0.437	0.38	0.50
1-1/2"	•	•	•		-	32	✓	0.75	1.56	0.749	0.437	0.38	0.62
1-3/4"	•	•			1, 2, 3, 4, 5, 6, 8, 10, 12	32		0.88	1.84	1.031	0.500	7/16	0.62
2"	•	•	•		-	32		0.88	2.08	1.374	0.625	0.50	0.75
2-1/2"	•	•			-	32		0.88	2.62	1.500	0.625	1/2	0.75
3"	•				-	32		1.25	3.16	1.630	0.750	5/8	0.88

Bore size									XJ			ZJ		
	EE	KK	KM	L	LB	PP	V	W	SR	SRM	Y	Z	SR	SRM
5/16"	#10-32	#5-40 UNC	3/8-24	0.19	-	0.34	-	0.31	2.03	-	-	0.125	2.19	-
7/16"	#10-32	#10-32 UNF	7/16-20	0.25	1.94	0.44	0.05	0.38	2.56	-	0.72	0.157	2.81	-
9/16"	#10-32	#10-32 UNF	7/16-20	0.25	-	0.38	0.06	0.38	2.56	2.81	0.78	0.157	2.75	3.00
3/4"	1/8 NPTF	1/4-28 UNF	5/8-18	0.34	2.91	0.62	0.09	0.50	3.75	3.75	0.97	0.251	4.03	4.03
7/8"	1/8 NPTF	1/4-28 UNF	5/8-18	0.34	-	0.62	0.09	0.50	3.56	-	0.97	0.251	3.84	-
1-1/16"	1/8 NPTF	5/16-24 UNF	5/8-18	0.34	-	0.62	0.09	0.62	3.84	-	1.19	0.251	4.12	4.28
1-1/4"	1/8 NPTF	7/16-20 UNF	3/4-16	0.41	-	0.78	0.09	0.88	4.72	4.75	1.62	0.251	5.12	5.16
1-1/2"	1/8 NPTF	7/16-20 UNF	3/4-16	0.50	-	0.81	0.09	0.88	4.38	4.63	1.50	0.376	4.75	5.00
1-3/4"	1/4 NPTF	1/2-20 UNF	1-14	0.50	4.19	1.12	0.09	1.06	5.75	5.75	1.94	0.376	6.25	6.25
2"	1/4 NPTF	1/2-20 UNF	1-1/4-12	0.56	-	1.03	0.12	1.19	5.62	5.91	-	0.376	6.06	6.34
2-1/2"	1/4 NPTF	1/2-20 UNF	1-3/8-12	0.56	-	1.03	0.13	1.19	5.62	5.62	1.84	0.376	6.06	6.06
3"	3/8 NPTF	5/8-18 UNF	1-1/2-12	0.81	-	1.34	0.19	1.38	6.50	-	2.09	0.500	7.12	-



Mounting Style DX

Threaded both ends, double acting

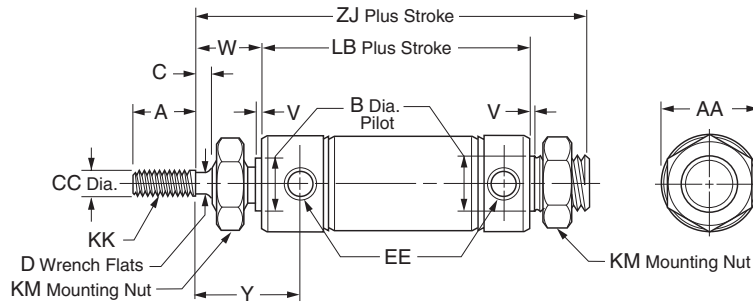

Bore size	SR	SRM	Std. stroke (in)	Max. stroke (in)	SS rod std
7/16" *	•		1/2, 1, 1-1/2, 2, 3, 4	12	✓
9/16" *	•	•	1/2, 1, 1-1/2, 2, 3, 4	12	✓
3/4" *	•	•	1, 2, 3, 4, 5, 6, 8, 10	32	✓
7/8" *	•	•	1, 2, 3, 4, 5, 6, 8, 10	32	✓
1-1/16" *	•	•	1/2, 1, 1-1/2, 2, 2-1/2, 3, 4, 5, 6, 8, 10, 12	32	✓
1-1/4" *	•	•	1, 2, 3, 4, 5, 6, 7, 8, 10, 12	32	✓
1-1/2"	•	•	1, 2, 3, 4, 5, 6, 8, 10, 12	32	✓
2" *	•	•	-	32	

Bore size	A	AA	B	C	CC	D	EE	KK	KM	LB			ZJ		
										SR	SRM	V	W	Y	SR
7/16" *	0.50	0.74	0.437	-	0.188	-	#10-32	#10-32 UNF	7/16-20	1.94		0.05	0.38	0.72	2.81
9/16" *	0.50	0.62	0.437	-	0.188	-	#10-32	#10-32 UNF	7/16-20	-		0.06	0.38	0.78	2.75
3/4" *	0.50	0.86	0.624	-	0.250	-	1/8 NPTF	1/4-28 UNF	5/8-18	2.91		0.09	0.50	0.97	4.03
7/8" *	0.50	0.93	0.624	-	0.250	-	1/8 NPTF	1/4-28 UNF	5/8-18	-		0.09	0.50	0.97	3.84
1-1/16" *	0.50	1.12	0.624	0.12	0.312	0.25	1/8 NPTF	5/16-24 UNF	5/8-18	-		0.09	0.62	1.19	4.12
1-1/4" *	0.75	0.34	0.749	0.25	0.437	0.38	1/8 NPTF	7/16-20 UNF	3/4-16	-		0.09	0.88	1.62	5.12
1-1/2"	0.75	1.56	0.749	0.25	0.437	0.38	1/8 NPTF	7/16-20 UNF	3/4-16	3.00		0.09	0.88	1.50	4.50
2" *	0.88	2.08	1.374	0.38	0.625	0.50	1/4 NPTF	1/2-20 UNF	1-1/4-12	-		0.12	1.19	-	6.06

* Available upon request. Please consult factory.

Mounting Style KDX

Threaded both ends, double acting, double rod

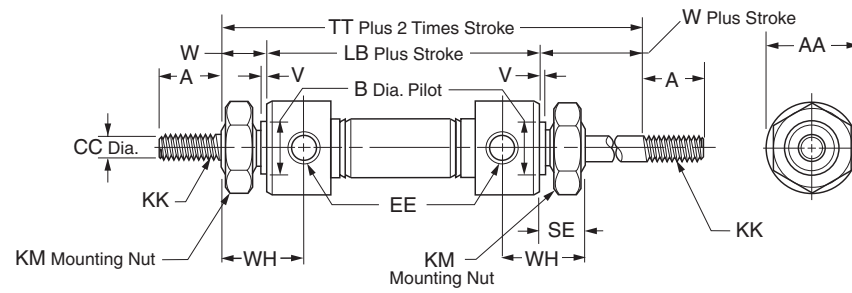

Bore sizes
7/16"
3/4"

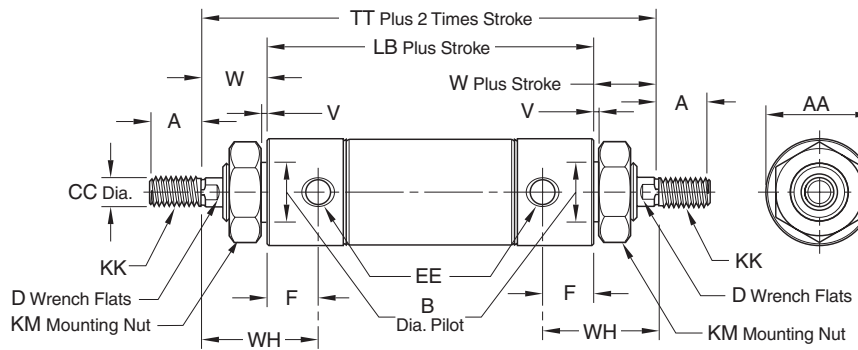

Bore sizes
9/16" *
7/8"
1-1/16"
1-1/4"
1-1/2"
1-3/4"
2" *
2-1/2" *
3" *

* No mounting nuts

Bore size	SR	SRM	SRD SRDM	Std. stroke (in)	Max. stroke (in)	SS rod	A	AA	B	CC
7/16"	•			1/2, 1, 1-1/2, 2, 3, 4	6	✓	0.50	0.74	0.437	0.188
9/16"	•	•	•	1/2, 1, 1-1/2, 2, 3, 4	6	✓	0.50	0.62	0.437	0.188
3/4"	•	•	•	1, 2, 3, 4, 5, 6	12	✓	0.50	0.86	0.624	0.250
7/8"	•			1, 2, 3, 4, 6	12	✓	0.50	0.93	0.624	0.250
1-1/16"	•	•	•	1, 2, 3, 4, 5, 6	12	✓	0.50	1.12	0.624	0.312
1-1/4"	•	•	•	1, 2, 3, 4, 5, 6	12	✓	0.75	1.34	0.749	0.437
1-1/2"	•	•	•	1, 2, 3, 4, 5, 6	12	✓	0.75	1.56	0.749	0.437
1-3/4"	•	•	•	1, 2, 3, 4, 5, 6	12	✓	0.88	1.84	1.031	0.500
2"	•	•	•	–	12	✓	0.88	2.08	1.374	0.625
2-1/2"	•	•	•	–	18	✓	0.88	2.62	1.500	0.625
3"	•	•	•	–	12	✓	1.25	3.16	1.630	0.750

Bore size	D	EE	F	KK	KM	LB			TT			V	W	WH
						SR	SRM	SE	SR	SRM	SE			
7/16"	–	#10-32	0.34	#10-32 UNF	7/16-20	2.06	–	0.38	2.81	–	0.05	0.38	0.72	
9/16"	–	#10-32	0.40	#10-32 UNF	7/16-20	2.19	2.44	0.38	2.94	3.19	0.06	0.38	0.78	
3/4"	–	1/8 NPTF	0.47	1/4-28 UNF	5/8-18	3.00	3.00	0.50	4.00	4.00	0.09	0.50	0.97	
7/8"	–	1/8 NPTF	0.47	1/4-28 UNF	5/8-18	2.91	–	0.50	3.91	–	0.09	0.50	0.97	
1-1/16"	0.25	1/8 NPTF	0.56	5/16-24 UNF	5/8-18	2.75	3.28	0.50	4.00	4.53	0.09	0.62	1.19	
1-1/4"	0.38	1/8 NPTF	0.75	7/16-20 UNF	3/4-16	3.81	3.84	0.63	5.56	5.59	0.09	0.88	1.62	
1-1/2"	0.38	1/8 NPTF	0.62	7/16-20 UNF	3/4-16	3.38	3.63	0.63	5.12	5.38	0.09	0.88	1.50	
1-3/4"	7/16	1/4 NPTF	0.88	1/2-20 UNF	1-14	4.44	4.69	0.75	6.56	6.81	0.09	1.06	1.94	
2"	0.50	1/4 NPTF	0.65	1/2-20 UNF	1-1/4-12	4.19	4.47	–	6.56	6.84	0.12	1.19	1.84	
2-1/2"	1/2	1/4 NPTF	0.65	1/2-20 UNF	1-3/8-12	4.19	4.19	–	6.56	6.56	0.13	1.19	1.84	
3"	5/8	3/8 NPTF	0.71	5/8-18 UNF	1-1/2-12	4.56	–	–	7.31	–	0.19	1.38	2.09	

Mounting Style RA

Nose mount, spring return, cap adjustable stroke

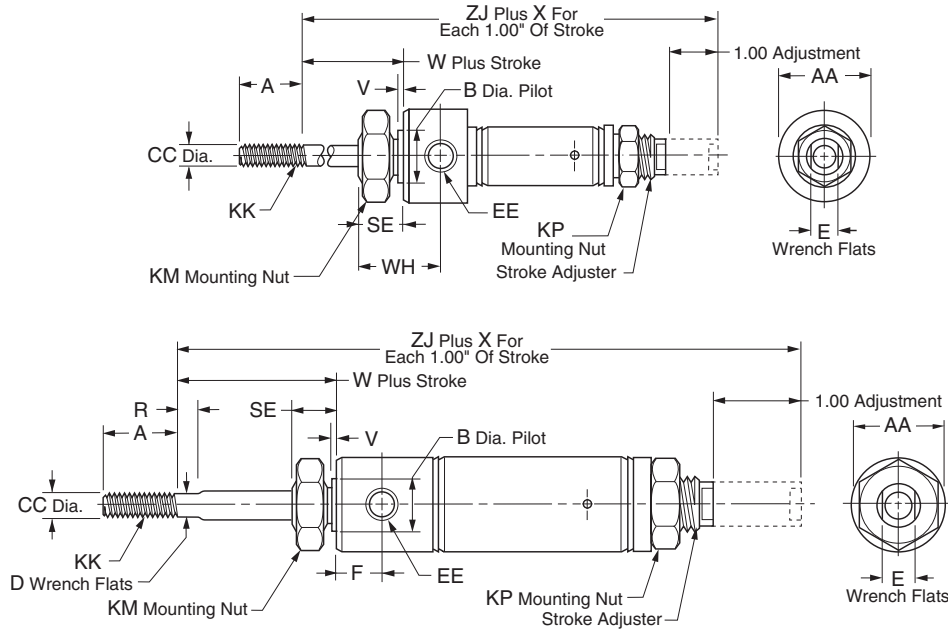

Bore sizes
3/4"
Bore sizes
1-1/16"
1-1/2"

Bore size	SR	SRM	Std. stroke	Max. stroke (in)	SS rod std
3/4"	•		Stroke adjustment in 1" increments to 3"	6	✓
1-1/16"	•		1" stroke adjusts 0-1"	6	✓
1-1/2"	•		2" stroke adjusts 1-2"	6	✓
			3" stroke adjusts 2-3"		

Bore size	A	AS	AA	B	CC	D	E	EE	F
3/4"	0.50	1.69	0.86	0.624	0.250	–	0.34	1/8 NPTF	–
1-1/16"	0.50	0.32	1.12	0.624	0.312	0.25	0.50	1/8 NPTF	0.56
1-1/2"	1.25	0.19	1.56	0.749	0.437	0.38	0.62	1/8 NPTF	0.62

Bore size	KK	KM	SE	R	V	W	WH	X	ZJ
3/4"	1/4-28 UNF	5/8-18	0.50	–	0.09	0.53	0.97	2.69	3.78
1-1/16"	5/16-24 UNF	5/8-18	0.50	0.12	0.09	0.50	–	2.56	4.03
1-1/2"	7/16-20 UNF	3/4-16	0.62	0.25	0.09	0.88	–	2.00	5.81



Mounting Style AP

Pivot mount, spring return, head adjustable stroke

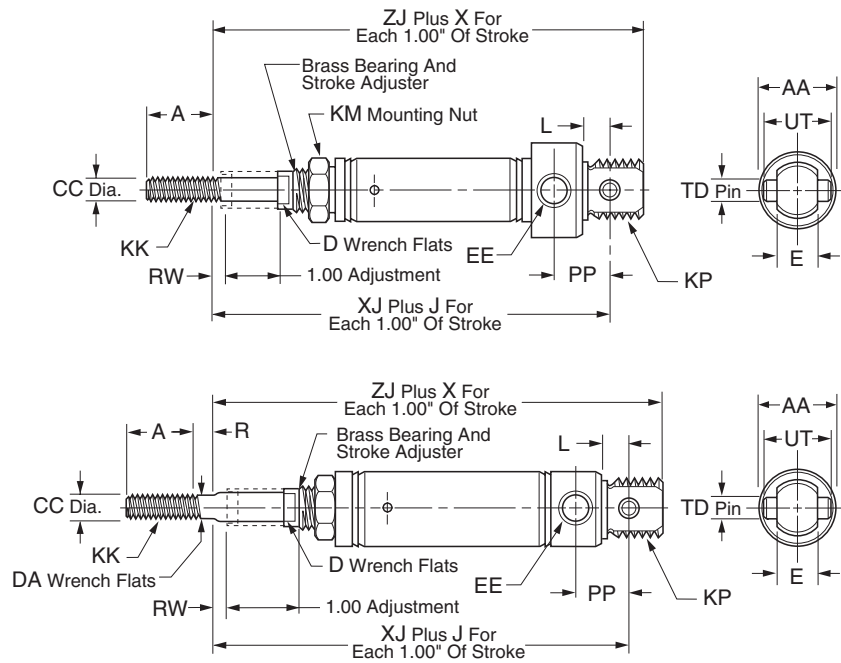

Bore sizes
3/4"

Bore sizes
1-1/16"
1-1/2"

Bore size	SR	SRM	Std. stroke	Max. stroke (in)	SS rod std
3/4"	•		Stroke adjustment in 1" increments to 3"	6	✓
1-1/16"	•		1" stroke adjusts 0-1" 2" stroke adjusts 1-2"	6	✓
1-1/2"	•		3" stroke adjusts 2-3"	6	✓

Bore size	A	AA	CC	D	DA	E	EE	J	KK
3/4"	0.50	0.86	0.250	0.34	–	0.38	1/8 NPTF	1.69	1/4-28 UNF
1-1/16"	0.50	1.12	0.312	0.50	0.25	0.38	1/8 NPTF	1.56	5/16-24 UNF
1-1/2"	0.75	1.56	0.437	0.62	0.38	0.62	1/8 NPTF	2.00	7/16-20 UNF

Bore size	KM	KP	L	OP	PP	R	RW	TD	UT	X	XJ	ZJ
3/4"	7/16-20	5/8-18 UNF	0.34	–	0.62	0.19	0.19	0.250	0.75	1.69	3.65	3.93
1-1/16"	–	5/8-18 UNF	0.34	0.25	0.62	0.12	0.25	0.250	0.75	1.56	3.97	4.25
1-1/2"	3/4-16	–	0.50	–	0.81	0.25	0.25	0.375	1.00	2.00	4.31	4.69

Mounting Style BRN

Rear block mount, single acting, spring return

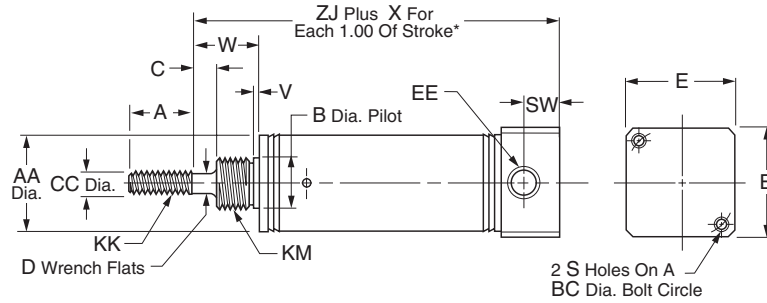

Bore size	SR	SRM	Std. stroke (in)	Max. stroke (in)	SS rod std	A	AA	B	C	CC	D
7/16"	•		1/2, 1, 2, 3, 4	6	✓	0.50	0.5	0.374	–	0.188	–
3/4"	•	•	1, 2, 3, 4	6	✓	0.75	0.81	0.499	0.25	0.250	0.22
1-1/16"	•	•	1, 2, 3, 4	6	✓	0.75	1.12	0.624	0.38	0.312	0.25
1-1/2"	•	•	1, 2, 3, 4	6	✓	1.25	1.56	0.749	0.25	0.437	0.38

Bore size	E	EE	KK	KM	SW	V	W	X	ZJ	
									SR	SRM
7/16"	0.75	#10-32	#10-32 UNF	3/8-24	0.38	0.05	0.31	0.94	1.62	–
3/4"	1.00	1/8 NPTF	1/4-28 UNF	1/2-20	0.44	0.09	0.62	1.69	2.31	2.56
1-1/16"	1.25	1/8 NPTF	5/16-24 UNF	5/8-18	0.44	0.09	0.88	1.81	2.81	3.06
1-1/2"	1.75	1/4 NPTF	7/16-20 UNF	3/4-16	0.62	0.09	0.88	2.00	3.06	3.31

* To determine lengths for half inch stroke increments, determine length for next highest whole number stroke and subtract one half inch.

Mounting Style BRR

Rear block mount, single acting, spring extend

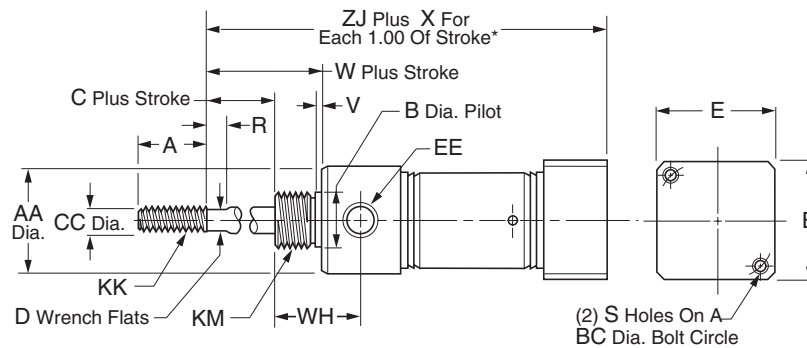

Bore size	SR	SRM	Std. stroke (in)	Max. stroke (in)	SS rod std	A	AA	B	BC	C	CC	D
3/4"	•	•	1, 2, 3, 4	6	✓	0.75	0.86	0.624	1.00	0.25	0.250	0.22
1-1/16"	•	•	1, 2, 3, 4	6	✓	0.75	1.12	0.624	1.25	0.38	0.312	0.25
1-1/2"	•	•	1, 2, 3, 4	6	✓	1.25	1.56	0.749	1.75	0.25	0.437	0.38

Bore size	E	EE	KK	KM	R	S	V	W	WH	X	ZJ	
											SR	SRM
3/4"	1.00	1/8 NPTF	1/4-28 UNF	5/8-18	0.25	#10-32 UNF	0.09	0.75	0.97	2.69	3.22	3.47
1-1/16"	1.25	1/8 NPTF	5/16-24 UNF	5/8-18	0.25	#10-32 UNF	0.09	0.88	1.06	2.81	3.53	3.78
1-1/2"	1.75	1/4 NPTF	7/16-20 UNF	3/4-16	0.25	1/4-20 UNC	0.09	0.88	1.25	3.00	3.88	4.13

* To determine lengths for half inch stroke increments, determine length for next highest whole number stroke and subtract one half inch.

Mounting Style BFD

Front block mount, double acting

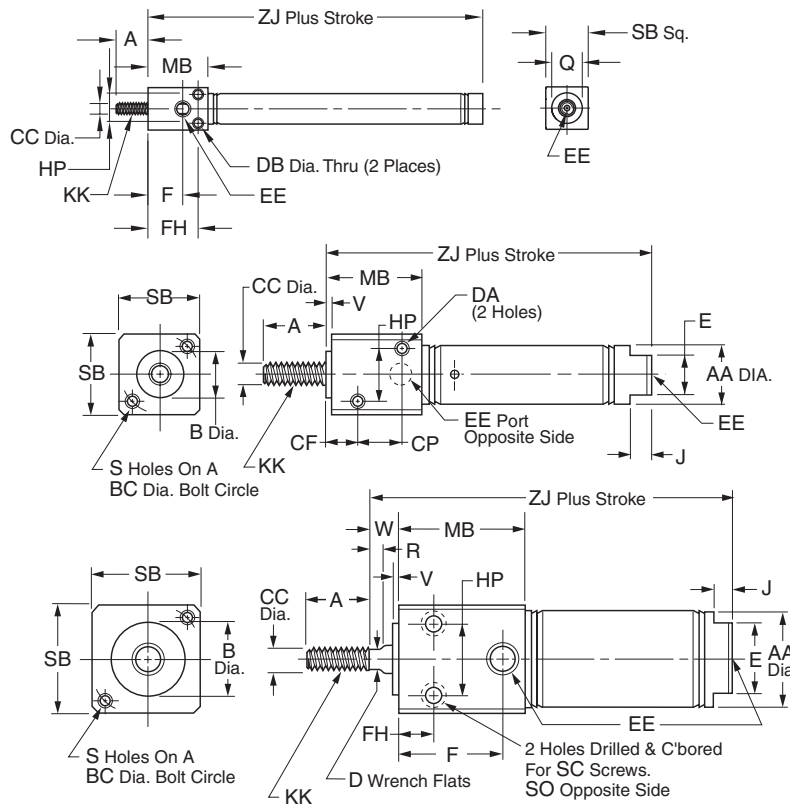

Bore sizes
5/16"

Bore sizes
7/16"

Bore sizes
3/4"
1-1/16"
1-1/2"

Bore size	SR	SRM	Std. stroke (in)	Max. stroke (in)	SS rod std	A	AA	B	BC	CC
5/16"	•		1/2, 1, 1-1/2, 2, 2-1/2, 3, 4	4	✓	0.38	-	-	-	0.125
7/16"	•		1/2, 1, 1-1/2, 2, 3, 4	12	✓	0.50	0.50	0.437	0.75	0.188
3/4"	•	•	1/2, 1, 2, 3, 4, 5, 6	12	✓	0.75	0.81	0.624	1.00	0.250
1-1/16"	•	•	1, 2, 3, 4, 5, 6	12	✓	0.75	1.12	0.750	1.25	0.312
1-1/2"	•	•	1, 2, 3, 4, 5, 6	12	✓	1.25	1.56	1.00	1.75	0.437

Bore size	CF	CP	D	DA	DB	E	EE	F	FH	HP	J
5/16"	-	-	-	-	0.11	-	#10-32	0.41	0.59	0.34	-
7/16"	0.31	0.44	-	#8-32	-	0.38	#10-32	-	0.31	0.44	0.19
3/4"	-	-	0.22	-	-	0.62	1/8 NPTF	0.88	0.38	0.62	0.19
1-1/16"	-	-	0.25	-	-	0.88	1/8 NPTF	1.16	0.62	0.81	0.19
1-1/2"	-	-	0.38	-	-	0.88	1/4 NPTF	1.53	0.88	1.12	0.25

Bore size	ZJ											
	KK	MB	Q	R	S	SB	SC	SO	V	W	SR	SRM
5/16"	#5-40 UNC	0.71	0.36	-	-	0.50 SQ	-	-	-	-	1.72	-
7/16"	#10-32 UNF	0.88	-	-	#8-32 UNC	0.75	-	-	0.062	-	2.12	-
3/4"	1/4-28 UNF	1.12	-	-	#10-32 UNF	1.00	#10-32	1/4-20 UNC	0.093	0.34	3.22	3.22
1-1/16"	5/16-24 UNF	1.41	-	0.25	#10-32 UNF	1.25	#10-32	1/4-20 UNC	0.093	0.47	3.75	3.91
1-1/2"	7/16-20 UNF	1.88	-	-	1/4-20 UNC	1.75	1/4-20	5/16-18 UNC	0.125	0.38	4.19	4.44

Mounting Style BRD

Rear block mount, double acting

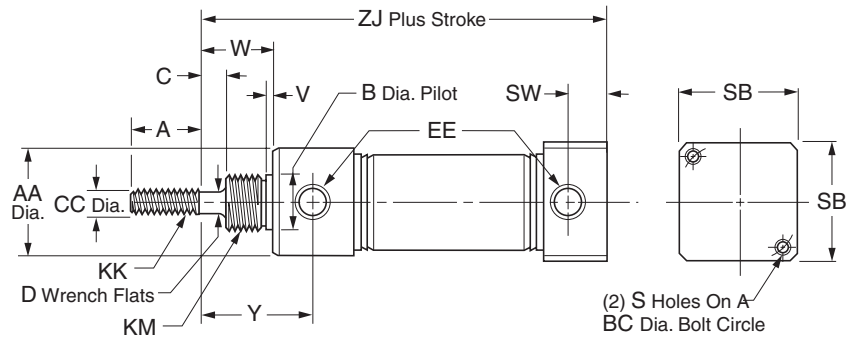

Bore size	SR	SRM	Std. stroke (in)	Max. stroke (in)	SS rod std
7/16"	•		1/2, 1, 2, 3, 4	12	✓
3/4"	•	•	1, 2, 3, 4, 5, 6	12	✓
1-1/16"	•	•	1, 2, 3, 4	12	✓
1-1/2"	•	•	1, 2, 3, 4, 5, 6	12	✓

Bore size	A	AA	B	BC	C	CC	D	EE	KK
7/16"	0.50	0.74	0.437	0.75	–	0.188	–	#10-32	#10-32 UNF
3/4"	0.75	0.86	0.624	1.00	0.25	0.250	0.22	1/8 NPTF	1/4-28 UNF
1-1/16"	0.75	1.12	0.624	1.25	0.38	0.312	0.25	1/8 NPTF	5/16-24 UNF
1-1/2"	1.25	1.56	0.749	1.75	0.25	0.437	0.38	1/4 NPTF	7/16-20 UNF

Bore size	KM	S	SB	SW	V	W	Y	ZJ	
								SR	SRM
7/16"	7/16-20 UNF	#8-32 UNC	0.75	0.38	0.05	0.43	0.72	2.44	–
3/4"	5/8-18 UNF	#10-32 UNF	1.00	0.44	0.09	0.75	1.22	3.78	3.78
1-1/16"	5/8-18 UNF	#10-32 UNF	1.25	0.44	0.09	0.88	1.44	4.00	4.16
1-1/2"	3/4-16 UNF	1/4-20 UNC	1.75	0.62	0.09	0.88	1.47	4.38	4.63

Mounting Style BFN

Front block mount, single acting, spring return

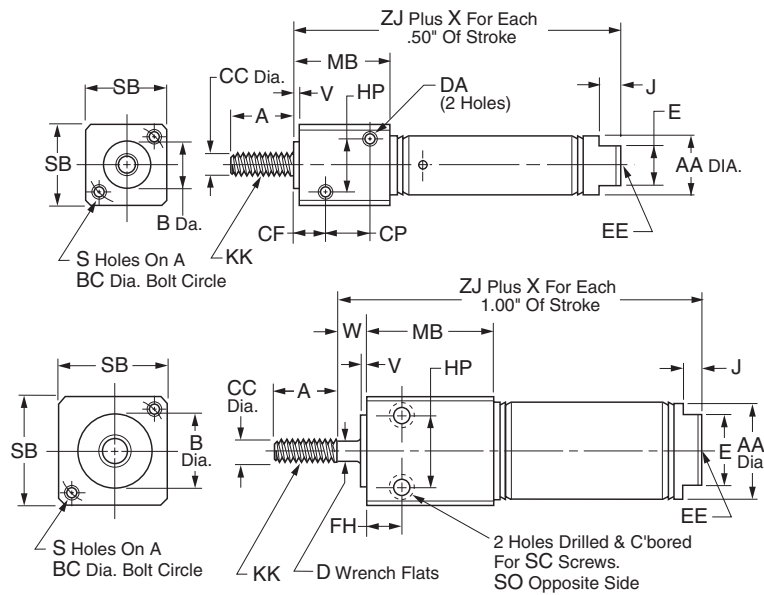

Bore sizes

7/16"

Bore sizes

3/4"

1-1/16"

1-1/2"

Bore size	SR	SRM	Std. stroke (in)	Max stroke (in)	SS rod std
7/16"	•		1/2, 1, 1-1/2, 2, 3	6	✓
3/4"	•	•	1/2, 1, 2, 3, 4	6	✓
1-1/16"	•	•	1, 2, 3, 4	6	✓
1-1/2"	•	•	1, 2, 3, 4	6	✓

Bore size	A	AA	B	BC	CC	CF	CP	D	DA	E	EE	FH
7/16"	0.50	0.50	0.437	0.75	0.188	0.31	0.44	-	#8-32 UNC	0.38	#10-32	0.31
3/4"	0.75	0.81	0.624	1.00	0.250	-	-	0.22	-	0.62	1/8 NPTF	0.38
1-1/16"	0.75	1.12	0.750	1.25	0.312	-	-	0.25	-	0.88	1/8 NPTF	0.62
1-1/2"	1.25	1.56	1.00	1.75	0.437	-	-	0.38	-	0.88	1/4 NPTF	0.88

Bore size	HP	J	KK	MB	S	SB	SC	SO	V	W	X	ZJ	
												SR	SRM
7/16"	0.44	0.19	#10-32 UNF	0.88	#8-32 UNC	0.75	-	-	0.062	-	0.94	1.94	-
3/4"	0.62	0.19	1/4-28 UNF	1.12	#10-32 UNF	1.00	#10-32	1/4-20 UNC	0.093	0.34	1.69	2.66	2.91
1-1/16"	0.81	0.19	5/16-24 UNF	1.41	#10-32 UNF	1.25	#10-32	1/4-20 UNC	0.093	0.47	1.81	3.38	3.63
1-1/2"	1.12	0.25	7/16-20 UNF	1.88	1/4 UNC	1.75	1/4-20	5/16-18 UNC	0.125	0.38	2.00	3.69	3.94

* To determine lengths for half inch stroke increments, determine length for next highest whole number stroke and subtract one half inch.

Mounting Style BFR

Front block mount, single acting, spring extend

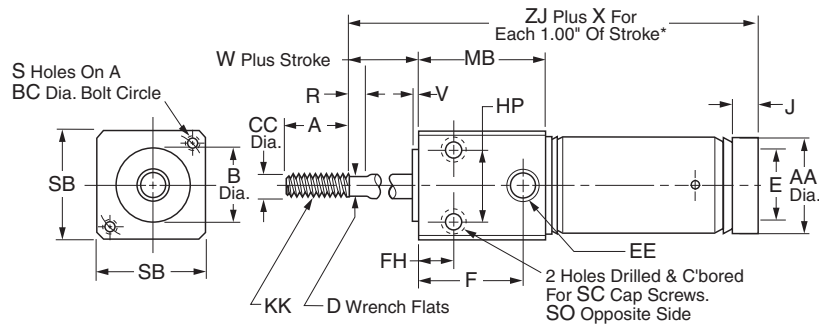

Bore size	SR	SRM	Std. stroke (in)	Max stroke (in)	SS rod std
3/4"	•	•	1, 2, 3, 4	6	✓
1-1/16"	•	•	1, 2, 3, 4	6	✓
1-1/2"	•	•	1, 2, 3, 4	6	✓

Bore size	A	AA	B	BC	CC	D	E	EE	F	FH	HP	J
3/4"	0.75	0.81	0.624	1.00	0.250	0.22	-	1/8 NPTF	0.88	0.38	0.62	0.19
1-1/16"	0.75	1.12	0.750	1.25	0.312	0.25	-	1/8 NPTF	1.16	0.62	0.81	-
1-1/2"	1.25	1.56	1.00	1.75	0.437	0.38	0.88	1/4 NPTF	1.53	0.88	1.12	0.25

Bore size	KK	MB	R	S	SB	SC	SO	V	W	X	ZJ	
											SR	SRM
3/4"	1/4-28 UNF	1.12	0.25	#10-32 UNF	1.00	#10-32	1/4-20 UNC	0.093	0.34	2.69	2.56	2.81
1-1/16"	5/16-24 UNF	1.41	0.25	#10-32 UNF	1.25	#10-32	1/4-20 UNC	0.093	0.47	2.81	3.12	3.37
1-1/2"	7/16-20 UNF	1.88	0.25	1/4-20 UNC	1.75	1/4-20	5/16-18 UNC	0.125	0.38	3.00	3.69	3.94

* To determine lengths for half inch stroke increments, determine length for next highest whole number stroke and subtract one half inch.

Mounting Style TRN

Rear trunnion mount, single acting, spring return

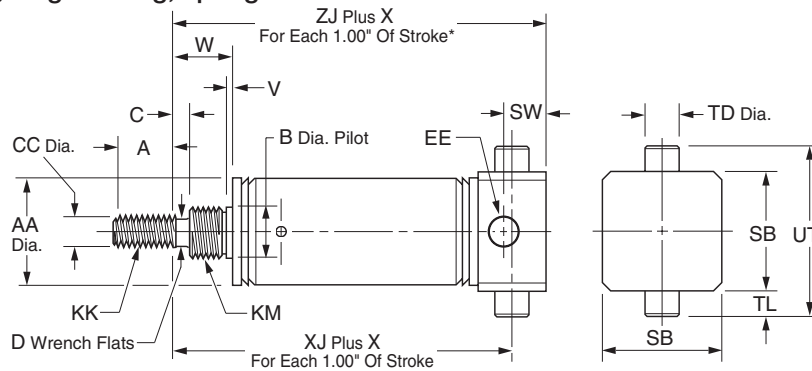

Bore size	SR	SRM	Std. stroke (in)	Max. stroke (in)	SS rod std	A	AA	B	C	CC	D	EE
3/4"	•	•	1, 2, 3, 4	6	✓	0.75	0.81	0.499	0.25	0.250	0.22	1/8 NPTF
1-1/16"	•	•	1, 2, 3, 4	6	✓	0.75	1.12	0.624	0.38	0.312	0.25	1/8 NPTF
1-1/2"	•	•	1, 2, 3, 4	6	✓	1.25	1.56	0.749	0.25	0.437	0.38	1/4 NPTF

Bore size	KK	KM	SB	SW	TD	TL	UT	V	W	X	XJ		ZJ	
											SR	SRM	SR	SRM
7/16"	#10-32 UNF	3/8-24 UNF	0.75	0.38	0.374	0.50	1.25	0.05	0.32	0.94**	1.38	–	1.62	–
3/4"	1/4-28 UNF	1/2-20 UNF	1.00	0.44	0.500	0.38	1.75	0.09	0.62	1.69	1.94	2.19	2.31	2.56
1-1/16"	5/16-24 UNF	5/8-18 UNF	1.25	0.44	0.500	0.38	2.00	0.09	0.88	1.81	2.44	2.69	2.81	3.06
1-1/2"	7/16-20 UNF	3/4-16 UNF	1.75	0.62	0.500	0.38	2.50	0.09	0.88	2.00	2.56	2.81	3.06	3.31

* To determine lengths for half inch stroke increments, determine length for next highest whole number stroke and subtract one half inch.

** For each 0.50" of stroke.

Mounting Style TRR

Rear trunnion mount, single acting, spring extend

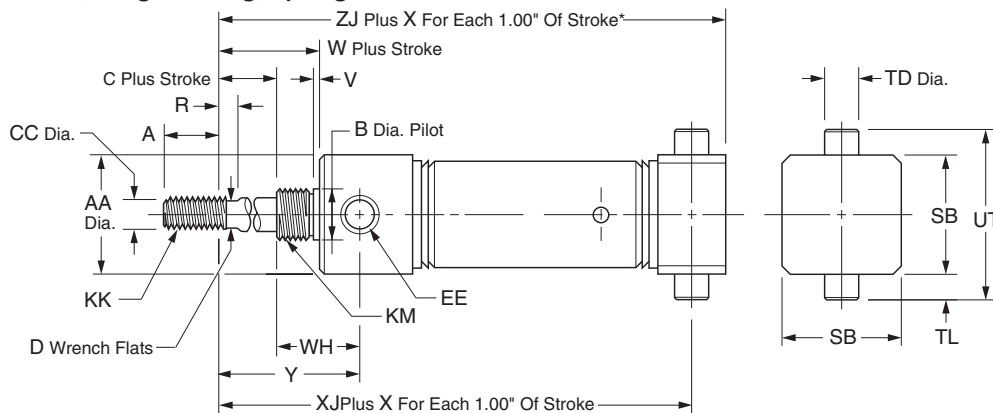

Bore size	SR	SRM	Std. stroke (in)	Max. stroke (in)	SS rod std	A	AA	B	C	CC	D	EE
1-1/16"			1, 2, 3, 4	6	3	0.75	1.12	0.624	0.38	0.312	0.25	1/8 NPTF
1-1/2"			1, 2, 3, 4	6	3	1.25	1.56	0.749	0.25	0.437	0.38	1/4 NPTF

Bore size	KK	KM	R	SB	TD	TL	UT	V	W	WH	X	XJ		ZJ	
												SR	SRM	SR	SRM
3/4"	1/4-28 UNF	1/2-20 UNF	0.25	1.00	0.500	0.38	1.75	0.09	0.75	0.72	2.69	2.85	3.10	3.22	3.47
1-1/16"	5/16-24 UNF	5/8-18 UNF	0.25	1.25	0.500	0.38	2.00	0.09	0.88	0.68	2.81	3.15	3.40	3.53	3.78
1-1/2"	7/16-20 UNF	3/4-16 UNF	0.25	1.75	0.500	0.38	2.50	0.09	0.88	1.25	3.00	3.38	3.63	3.88	4.13

* To determine lengths for half inch stroke increments, determine length for next highest whole number stroke and subtract one half inch.



Mounting Style TFD

Front trunnion mount, double acting

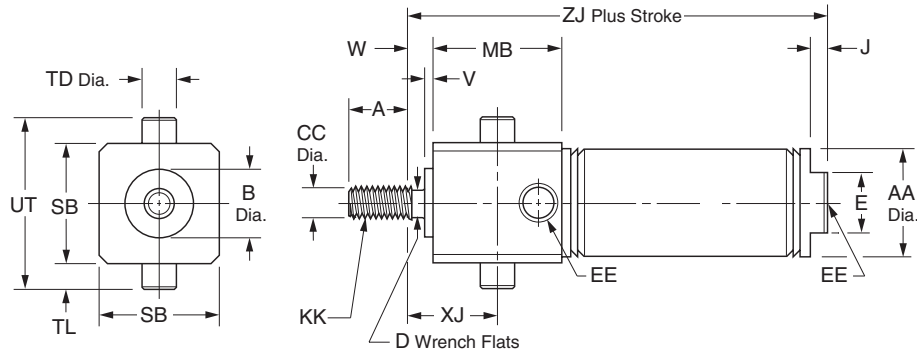

Bore size	SR	SRM	Std. stroke (in)	Max. stroke (in)	SS rod std	A	AA	B	CC	D	E	EE
7/16"	•		1/2, 1, 1-1/2, 2, 3, 4	12	✓	0.50	0.50	0.437	0.188	–	0.38	#10-32
3/4"	•	•	1, 2, 3, 4, 5, 6	12	✓	0.75	0.81	0.624	0.250	0.22	0.62	1/8 NPTF
1-1/16"	•	•	1, 2, 3, 4, 5, 6	12	✓	0.75	1.12	0.750	0.312	0.25	0.88	1/8 NPTF
1-1/2"	•	•	1, 2, 3, 4, 5, 6	12	✓	1.25	1.56	1.000	0.437	0.38	0.88	1/4 NPTF

Bore size	J	KK		MB	SB	TD	TL	UT	V	W	XJ	ZJ	
	0.19	#10-32 UNF	SR									SRM	
7/16"	0.19	1/4-28 UNF	0.88	0.75	0.374	0.250	1.25	0.062	–	0.31	2.12	–	–
3/4"	0.19	5/16-24 UNF	1.12	1.00	0.500	0.38	1.75	0.093	0.34	0.69	3.22	3.22	–
1-1/16"	0.25	7/16-20 UNF	1.41	1.25	0.500	0.38	2.00	0.093	0.47	1.09	3.75	3.91	–
1-1/2"			1.88	1.75	0.500	0.38	2.50	0.125	0.38	1.31	4.19	4.44	–

Mounting Style TRD

Rear trunnion mount, double acting

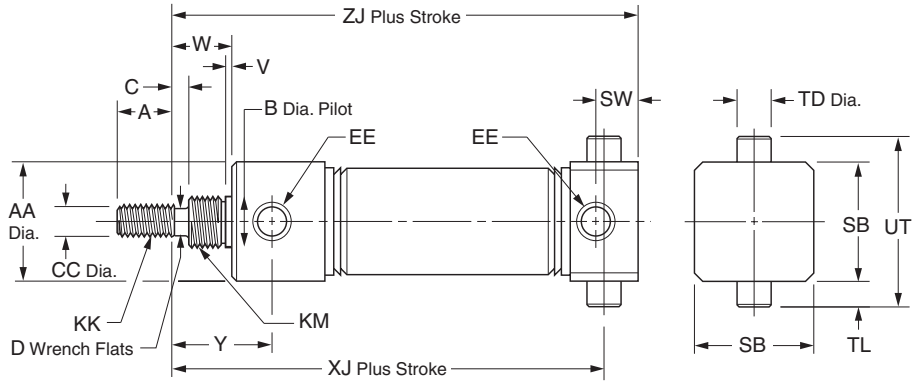

Bore size	SR	SRM	Std. stroke (in)	Max. stroke (in)	SS rod std	A	AA	B	C	CC	D	EE
7/16"	•		1/2, 1, 1-1/2, 2, 3, 4	12	✓	0.50	0.74	0.437	–	0.188	–	#10-32
3/4"	•	•	1, 2, 3, 4, 5, 6	12	✓	0.75	0.86	0.624	0.25	0.250	0.22	1/8 NPTF
1-1/16"	•	•	1, 2, 3, 4	12	✓	0.75	1.12	0.624	0.38	0.312	0.25	1/8 NPTF
1-1/2"	•	•	1, 2, 3, 4, 5, 6	12	✓	1.25	1.56	0.749	0.25	0.437	0.38	1/4 NPTF

Bore size	KK		KM		SB	SW	TD	TL	UT	V	W	XJ		ZJ	
	#10-32 UNF	7/16-20 UNF	SR	SRM								Y	SR	SRM	
7/16"	1/4-28 UNF	5/8-18 UNF	0.75	0.38	0.374	0.25	1.25	0.05	0.38	2.19	–	0.72	2.44	–	–
3/4"	5/16-24 UNF	5/8-18 UNF	1.00	0.44	0.500	0.38	1.75	0.09	0.75	3.41	3.41	1.22	3.78	3.78	–
1-1/16"	7/16-20 UNF	3/4-16 UNF	1.25	0.44	0.500	0.38	2.00	0.09	0.88	3.62	3.62	1.44	4.00	4.16	–
1-1/2"			1.75	0.62	0.500	0.38	2.50	0.09	0.88	3.88	4.13	1.47	4.38	4.63	–

Mounting Style TFN

Front trunnion mount, single acting, spring return

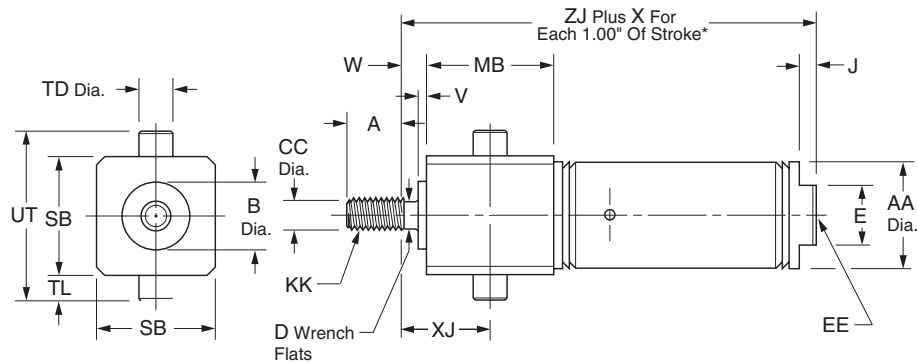

Bore size	SR	SRM	Std. stroke (in)	Max. stroke (in)	SS rod std	A	AA	B	CC	D	E	EE
7/16"	•		1/2, 1, 1-1/2, 2, 3	6	✓	0.50	0.50	0.437	0.188	-	0.38	#10-32
3/4"	•	•	1/2, 1, 2, 3, 4	6	✓	0.75	0.81	0.624	0.250	0.22	0.62	1/8 NPTF
1-1/16"	•	•	1, 2, 3, 4	6	✓	0.75	1.12	0.750	0.312	0.25	0.88	1/8 NPTF
1-1/2"	•	•	1, 2, 3, 4	6	✓	1.25	1.56	1.000	0.437	0.38	0.88	1/4 NPTF

Bore size	J		KK										ZJ	
	0.19	#10-32 UNF	MB	SB	TD	TL	UT	V	W	X	XJ	SR	SRM	
7/16"	0.19	1/4-28 UNF	0.88	0.75	0.374	0.25	1.25	0.062	0	0.94**	0.31	1.94	-	
3/4"	0.19	5/16-24 UNF	1.12	1.00	0.500	0.38	1.75	0.093	0.34	1.69	0.69	2.66	2.91	
1-1/16"	0.25	7/16-20 UNF	1.41	1.25	0.500	0.38	2.00	0.093	0.47	1.81	1.09	3.38	3.63	
1-1/2"			1.88	1.75	0.500	0.38	2.50	0.125	0.38	2.00	1.31	3.69	3.94	

* To determine lengths for half inch stroke increments, determine length for next highest whole number stroke and subtract one half inch.

** For each 0.50" of stroke

Mounting Style TFR

Front trunnion mount, single acting, spring extend

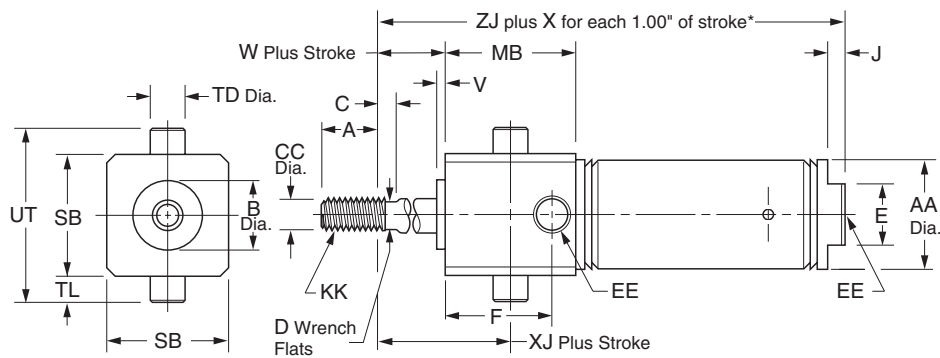

Bore size	SR	SRM	Std. stroke (in)	Max. stroke (in)	SS rod std	A	AA	B	C	CC	D	E
3/4"	•	•	1, 2, 3, 4	6	✓	0.75	0.81	0.624	0.25	0.250	0.22	0
1-1/16"	•	•	1, 2, 3, 4	6	✓	0.75	1.12	0.750	0.25	0.312	0.25	0
1-1/2"	•	•	1, 2, 3, 4	6	✓	1.25	1.56	1.000	0.25	0.437	0.38	0.88

Bore size	ZJ														
	F	EE	J	KK	MB	SB	TD	TL	UT	V	W	X	XJ	SR	SRM
3/4"	0.88	1/8 NPTF	-	1/4-28 UNF	1.12	1.00	0.500	0.38	1.75	0.093	0.34	2.69	0.69	2.56	2.81
1-1/16"	1.16	1/8 NPTF	-	5/16-24 UNF	1.41	1.25	0.500	0.38	2.00	0.093	0.47	2.81	1.09	3.12	3.37
1-1/2"	-	1/4 NPTF	0.25	7/16-20 UNF	1.88	1.75	0.500	0.38	2.50	0.125	0.38	3.00	1.31	3.69	3.94

* To determine lengths for half inch stroke increments, determine length for next highest whole number stroke and subtract one half inch.



Air Reservoirs

Air Reservoirs installed can significantly reduce the pulsation of a system. In addition air reservoirs can be used as a means to store energy. Caution should always be used when storing energy. Air reservoirs if installed in the correct location and sized correctly can temporarily increase the flow of an actuator or cylinder.

As always never exceed the rated pressure of the cylinder.

Ordering information

<div style="border: 1px solid black; padding: 5px; width: fit-content; margin: 0 auto;">.75</div> <div style="border: 1px solid black; padding: 5px; width: fit-content; margin: 5px auto;"> Bore Size* <table border="1" style="width: 100%; border-collapse: collapse;"> <tr><td>.75</td><td>3/4"</td></tr> <tr><td>1.06</td><td>1-1/16"</td></tr> <tr><td>1.50</td><td>1-1/2"</td></tr> <tr><td>2.00</td><td>2"</td></tr> <tr><td>2.50</td><td>2-1/2"</td></tr> <tr><td>3.00</td><td>3"</td></tr> </table> </div>	.75	3/4"	1.06	1-1/16"	1.50	1-1/2"	2.00	2"	2.50	2-1/2"	3.00	3"	<div style="border: 1px solid black; padding: 5px; width: fit-content; margin: 0 auto;">AR</div> <div style="border: 1px solid black; padding: 5px; width: fit-content; margin: 5px auto;"> Mounting <table border="1" style="width: 100%; border-collapse: collapse;"> <tr><td>AR</td><td>Air Reservoir</td></tr> </table> </div>	AR	Air Reservoir	<div style="border: 1px solid black; padding: 5px; width: fit-content; margin: 0 auto;">SR</div>	<div style="border: 1px solid black; padding: 5px; width: fit-content; margin: 0 auto;">2.00</div> <div style="border: 1px solid black; padding: 5px; width: fit-content; margin: 5px auto;"> Length Specify in inches. See table below. </div>
.75	3/4"																
1.06	1-1/16"																
1.50	1-1/2"																
2.00	2"																
2.50	2-1/2"																
3.00	3"																
AR	Air Reservoir																

Bore size	Standard lengths	Max. length	Volume (in3)
3/4"	1" increments to 4"	32"	0.39 plus 0.44 per inch length
1-1/16"	1" increments to 8"	32"	0.99 plus 0.89 per inch length
1-1/2"	1" increments to 16"	32"	1.91 plus 1.77 per inch length
2"	1" increments to 16"	32"	4.22 plus 3.14 per inch length
2-1/2"	1" increments to 16"	32"	7.04 plus 4.91 per inch length
3"	1" increments to 16"	32"	9.90 plus 7.07 per inch length

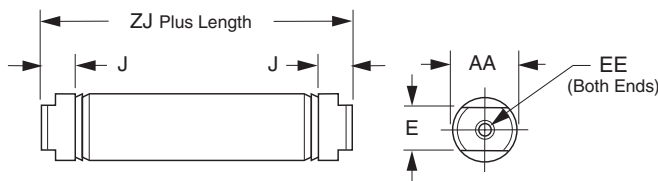

Bore size	AA	E	EE	J	ZJ
3/4"	0.813	0.625	1/8" NPTF	0.19	1.938
1-1/16"	1.125	0.88	1/8" NPTF	0.19	2.375
1-1/2"	1.56	0.88	1/8" NPTF	0.250	2.250
2"	2.08	1.25	1/4" NPTF	0.562	2.875
2-1/2"	2.62	1.75	1/4" NPTF	0.562	2.875
3"	3.16	2.00	3/8" NPTF	0.562	3.190

Piston Rod Clevis

Assembly includes pin and (2) retainer rings and (1) jam nut.

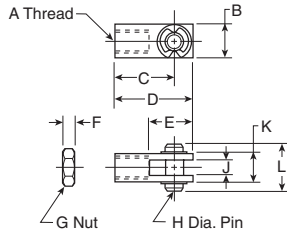

Bore size	A	B	C	D	E	F	G	H	J	K	L	Part number
5/16	#5-40	.31	.44	.56	.38	.11	#5-40	.12	.13	.31	.50	L071300025
7/16, 9/16	#10-32	.38	.75	.94	.56	.12	#10-32	.19	.19	.38	.56	L071300100 L077130100*
3/4, 7/8	1/4-28	.50	.94	1.19	.68	.16	1/4-28	.25	.25	.50	.69	L071300200 L077130200*
1-1/16	5/16-24	.50	.94	1.19	.68	.19	5/16-24	.25	.25	.50	.69	L071300300 L077130300*
1-1/4, 1-1/2	7/16-20	.75	1.31	1.69	.94	.25	7/16-20	.38	.38	.75	1.03	L071300400 L077130400*
1-3/4, 2, 2-1/2	1/2-20	.75	1.31	1.69	.94	.31	1/2-20	.38	.38	.75	1.03	L071300500 L077130500*
3	5/8-18	1.00	2.25	2.75	1.50	.38	5/8-18	.50	.50	1.00	1.38	L071300600

* Stainless Steel for use with SRD/SRDM cylinders.

Pivot Brackets

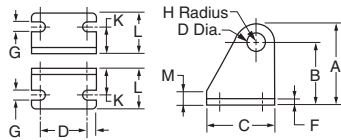

Bore size	A	B	C	D	E	F	G	H	J	K	L	M	Part number
7/16	.76	.56	.75	.50	.12	.06	.19	.20	.160	.28	.50	.12	L071310100
3/4, 7/8, 1-1/16	1.19	.88	1.12	.75	.19	.12	.27	.31	.255	.44	.81	.25	L071310200
1-1/2	1.75	1.38	1.50	1.00	.25	.12	.27	.38	.380	.62	1.00	.25	L071310300

Pivot Bracket Assembly

Assembly includes pin and (2) retainer rings.

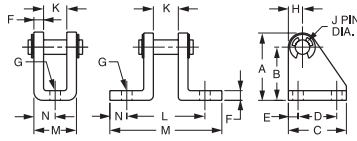

5/16" bore only

Bore size	A	B	C	D	E	F	G	H	J	K	L	M	N	Part number
5/16	.53	.40	.62	.38	.12	.04	.16	.12	.12	.26	-	.36	.18	L071320025
7/16, 9/16	.76	.56	.75	.50	.12	.06	.19	.19	.156	.34	.91	1.34	.22	L071320100 L077150100*
3/4, 7/8, 1-1/16	1.18	.88	1.12	.75	.19	.12	.27	.30	.250	.38	1.25	2.00	.38	L071320200 L077150200*
1-1/4	1.18	.88	1.12	.75	.19	.12	.27	.30	.250	.50	1.38	2.14	.38	L071320300
1-1/2, 1-3/4	1.75	1.38	1.50	1.00	.25	.25	.27	.37	.375	.62	2.00	2.88	.44	L071320400 L077150400*
2, 2-1/2	1.75	1.38	1.50	1.00	.25	.25	.27	.37	.375	.75	2.12	3.00	.44	L071320500 L077150500*
3	2.25	1.75	1.75	1.25	.25	.25	.27	.50	.50	.88	2.62	3.88	.62	L071320600

* Stainless steel for use with SRD/SRDM cylinders.

SR Series Trunnion Brackets

Select brackets for SR series trunnion mount cylinders from the table below. (Note: trunnion brackets are ordered as a separate item from the cylinder.)

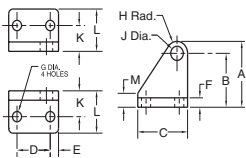

Bore size	A	B	C	D	E	F	G	H	J	K	L	M	Part number
7/16	1.75	1.38	1.50	1	.25	.25	.27	.38	.375	.69	1.12	.37	L076600100
3/4, 1-1/16, 1-1/2	1.75	1.38	1.50	1	.25	.25	.27	.38	.500	.69	1.12	.37	L076600200

Most popular.



Foot Brackets

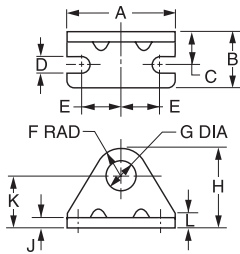

Bore size	A	B	C	D	E	F	G	H	J	K	L	Part number
5/16	1.00	.37	.25	.13	.37	.31	.25	.75	.06	.44	.12	L073790016
5/16	1.00	.37	.25	.13	.37	.31	.38	.75	.06	.44	.12	L073790023
7/16	1.38	.62	.31	.19	.50	.31	.38	.88	.07	.56	.12	L073790024
7/16, 9/16	1.38	.62	.38	.19	.50	.38	.44	.94	.09	.56	.12	L073790028 L077160028*
3/4	1.62	.75	.44	.19	.62	.41	.50	1.09	.10	.69	.19	L073790032
3/4, 7/8, 1-1/16	1.88	1.00	.56	.27	.75	.56	.63	1.38	.12	.81	.25	L073790040 L077160040*
1-1/4, 1-1/2	2.50	1.50	.75	.27	.94	.75	.75	1.75	.12	1.00	.38	L073790048 L077160048*
1-3/4	3.00	1.50	.87	.35	1.12	.91	1.03	2.16	.19	1.25	.50	L073790102
2	3.12	1.62	1.00	.34	1.12	1.00	1.38	2.50	.25	1.50	.62	L073790124 L077160124*
2-1/2	3.75	1.62	1.00	.35	1.44	1.25	1.51	3.00	.25	1.75	.75	L073790132
3	4.37	1.62	1.00	.35	1.75	1.25	1.64	3.14	.25	1.89	.89	L073790140

* Stainless Steel for use with SRD/SRDM cylinders.

Mounting Nut

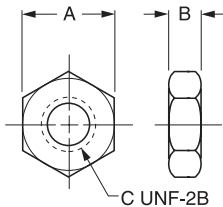

Bore size	A	B	C	Part number
5/16	.44	.16	1/4-28	L073800200
5/16, 7/16	.56	.22	3/8-24	L073800400
7/16, 9/16	.69	.25	7/16-20	L073800500 L077170500*
3/4	.75	.31	1/2-20	L073800600
3/4, 7/8, 1-1/16	.94	.38	5/8-18	L073800800 L077170800*
1-1/4, 1-1/2	1.12	.42	3/4-16	L073800900
1-1/4, 1-1/2	1.12	.72	3/4-16	L077170900*
1-3/4	1.50	.55	1-14	L073801100
2	1.88	.50	1-1/4-12	L073801200 L077171200*
2-1/2	2.06	.78	1-3/8-12	L073801400
3	2.25	.84	1-1/2-12	L073801500

* Stainless Steel for use with SRD/SRDM cylinders.

Most popular.



SRX Series

- Continuous position feedback
- Bore sizes: 1-1/16" to 3"
- Signal input: 5 to 24 VDC
- Signal output (w/o controls): DC ratiometric voltage*
- Signal output (w/controls): 0 to 10 VDC or 4 to 20 mA
- Strokes: Available in any practical stroke length up to 24"

* Mega Ohm impedance interface device suggested for limiting sensor current if controller is not used.

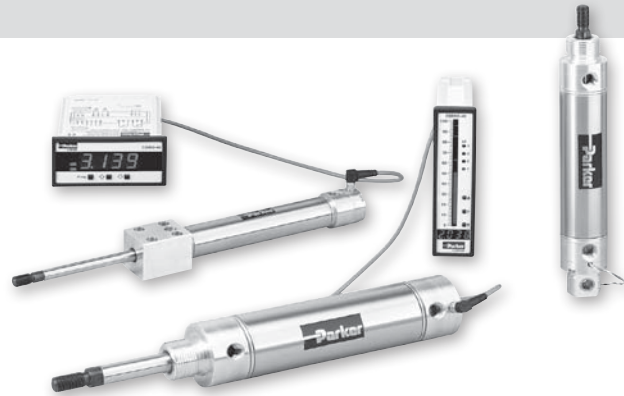

Operating information

Operating pressure:	150 PSIG (10.3 bar)
Temperature range:	40°F to 160°F (4.4°C to 71°C)
Filtration requirements:	40 micron, dry filtered air

Ordering information

1.50"	DXP	P	SRX	B	F	S	3	6.00"
Bore size		Connector style		Piston		Special		Stroke
1.06"		P Plug		B Bumper*		S Special		Stroke in inches
1.50"		F Flying leads		Leave blank if not required.		Leave blank if special modification is not required.		
2.00"								
2.50"								
3.00"								
	Mounting style				Seals		Non-standard rod dimension	
	D Nose mount				F Low friction		3 Non-standard dimension	
	DXP Nose and pivot mount				Leave blank if not required.		Leave blank if special rod end dimension is not required.	
	BFD Front block mount							

* Incorporating bumpers adds 1/4" of overall length to the cylinder.

Sensors
 For sensors see page 39-42.

NOTE: For non-standard / special rod ends, see below.

For ordering purposes, when special options or common modifications are requested, the factory will assign a sequential part number in place of the model number.

Non-standard rods

For non-standard rod dimensions, or undersized rod end threads, put a "3" in model number and describe the rod using the letters shown in the drawing. It is necessary to specify only those dimensions that are non-standard. LE is measured in retracted position.

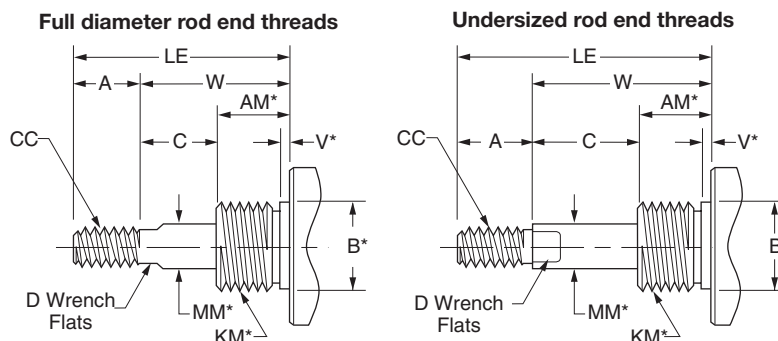

* Requires an "S" designation in model number.

Dual Set Point Controller, Part #149344000

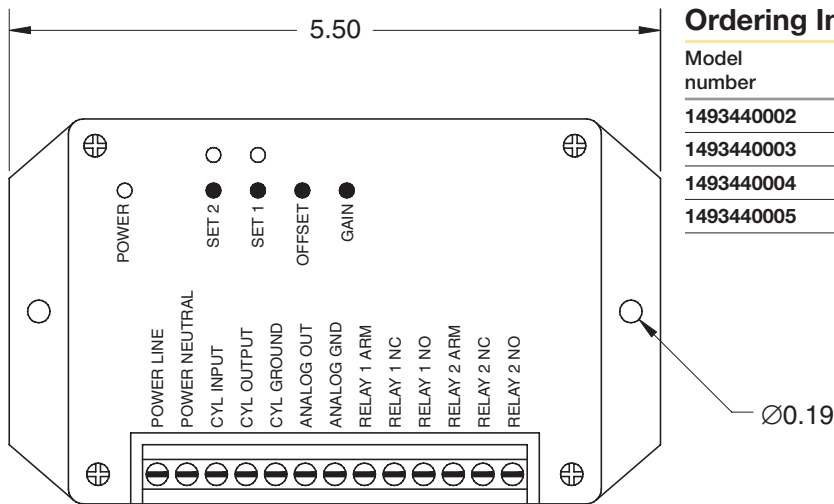

Ordering Information

Model number	Input specifications	Output specifications
1493440002	120 VAC	0-10 V
1493440003	120 VAC	4-20 mA
1493440004	12-24 VDC	0-10 V
1493440005	12-24 VDC	4-20 mA

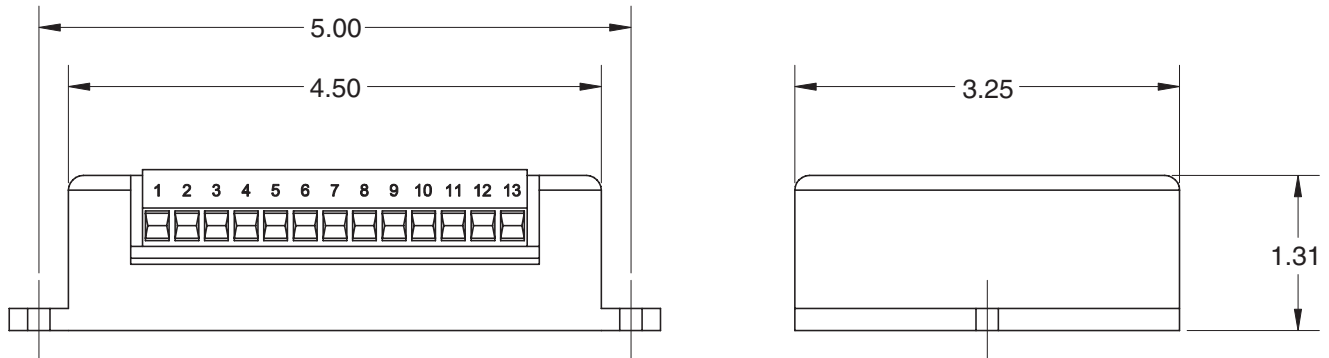

Dual Set Point Controller Specifications, Part #149344000

- Power Input Requirements..... 12 to 24 VDC, 0.1 amps, or 120 VAC, 60 Hz, 0.1 amps
- Output specifications – Set PointRelay (2) 2 amps @ 24 VDC or 120 VAC
- Output Specifications – Scaleable0 to 10 V, 1 mA max. output current (10K ohm impedance min.) 4 to 20mA, into 500-ohm max. impedance
- Maximum Zero Offset.....50% of cylinder stroke
- Minimum Span Range.....50% of cylinder stroke
- Enclosure Dimensions..... 1.31" h x 5.50" w x 3.25" d
- Electronics Temperature Operating Range +40°F to +160°F

Please reference Parker Bulletin #0971-G-B2 for information regarding programming and operation of this controller.

1-1/16" Bore Cylinders

Style D

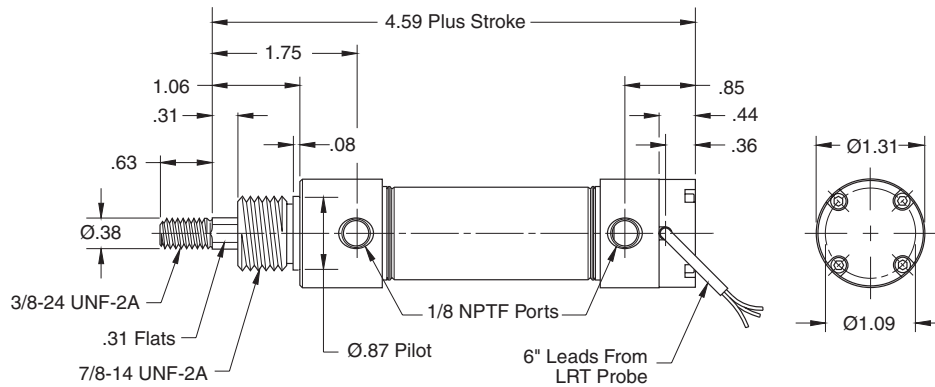

Style DXP

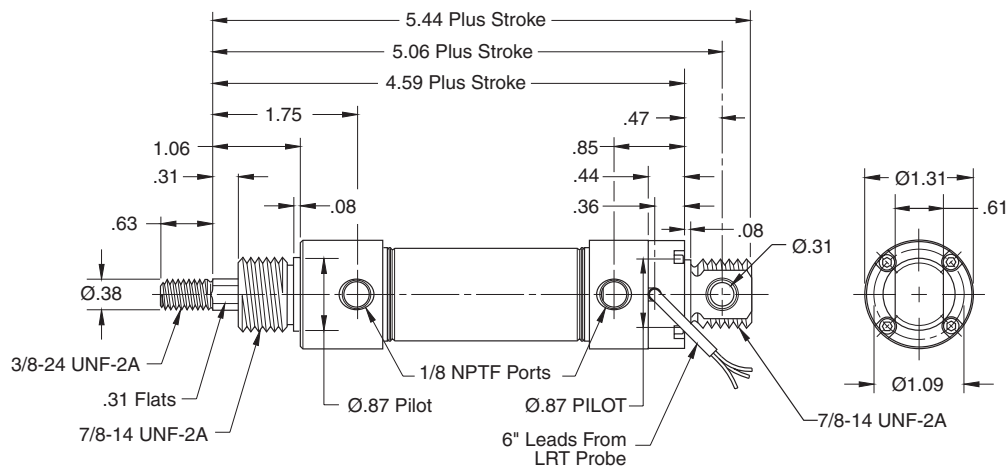

Style BFD

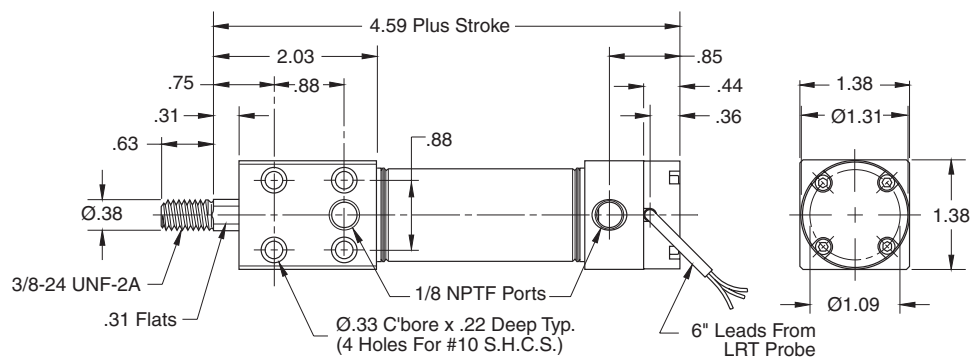

1-1/2" Bore Cylinders

Style D

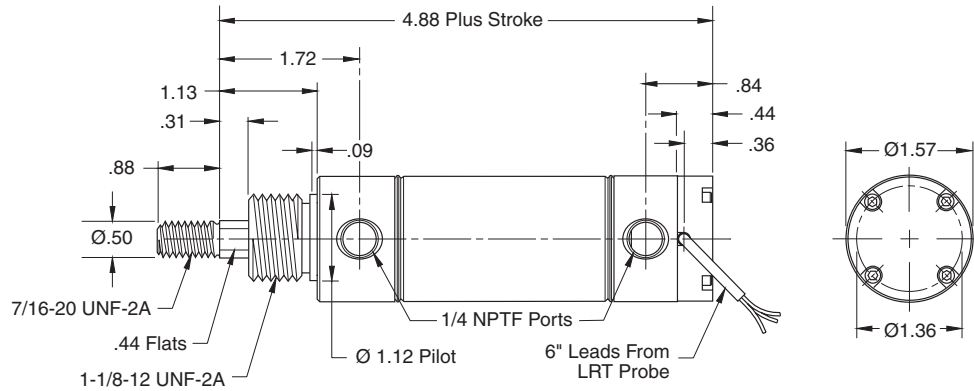

Style DXP

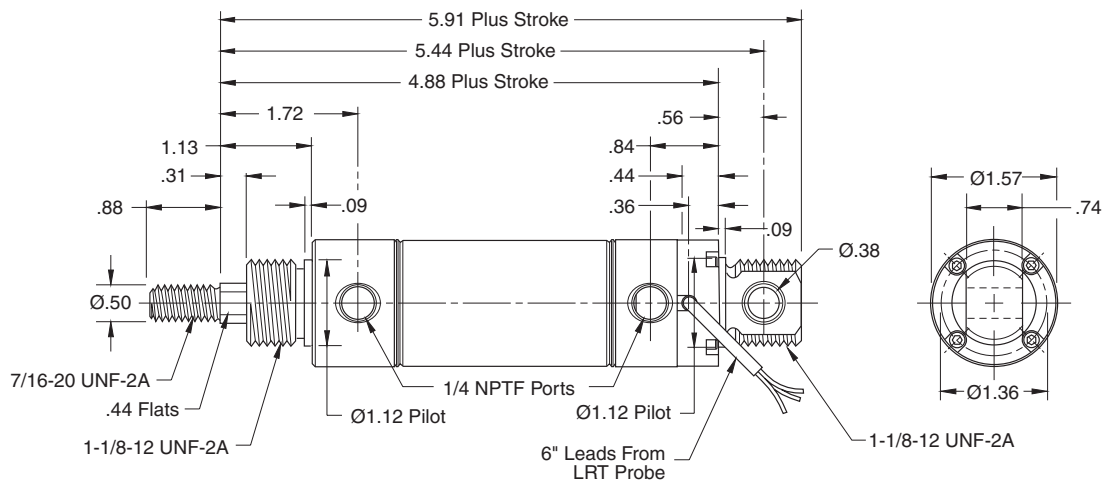

Style BFD

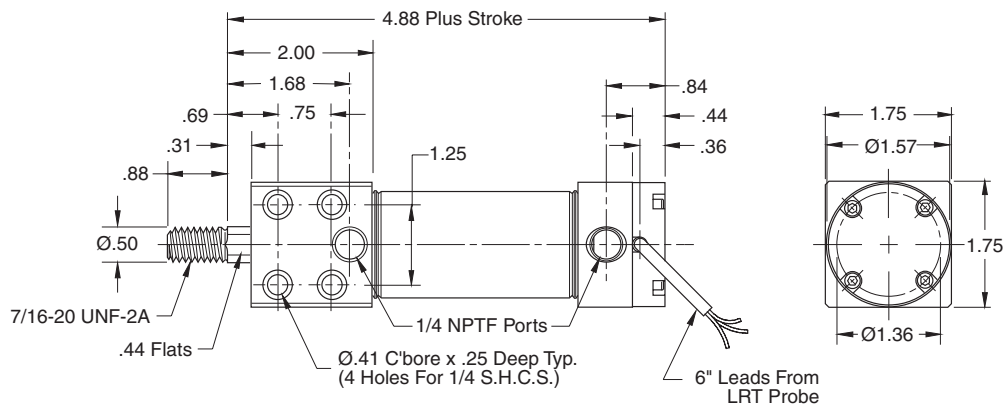

2" Bore Cylinders

Style D

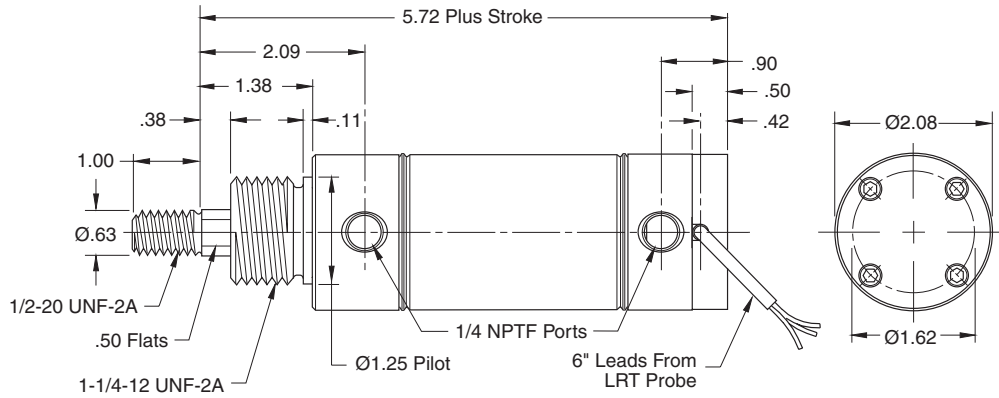

Style DXP

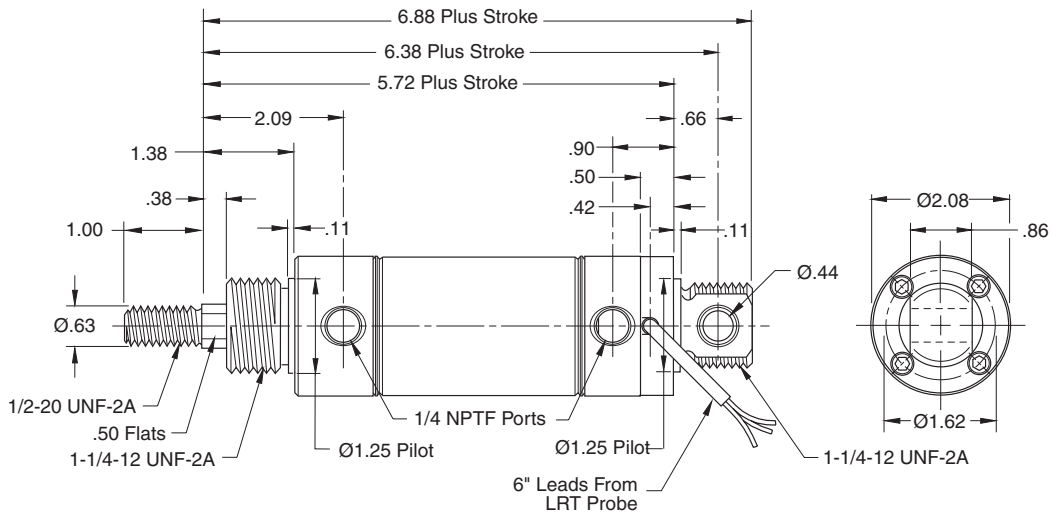

Style BFD

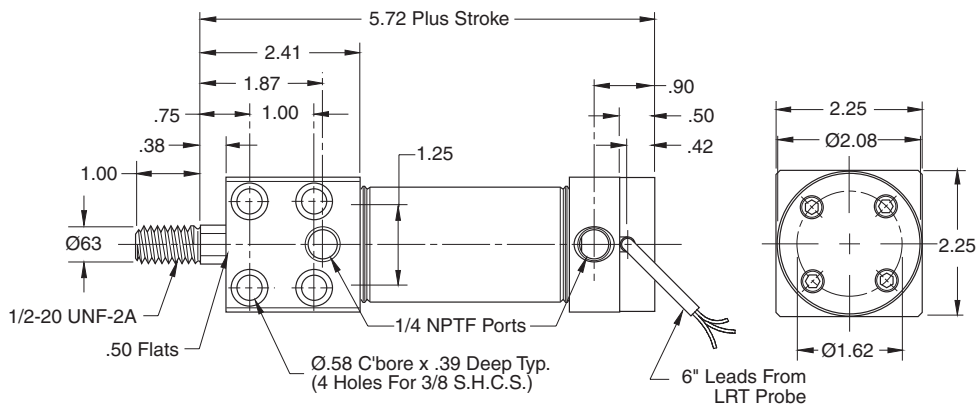

2-1/2" Bore Cylinders

Style D

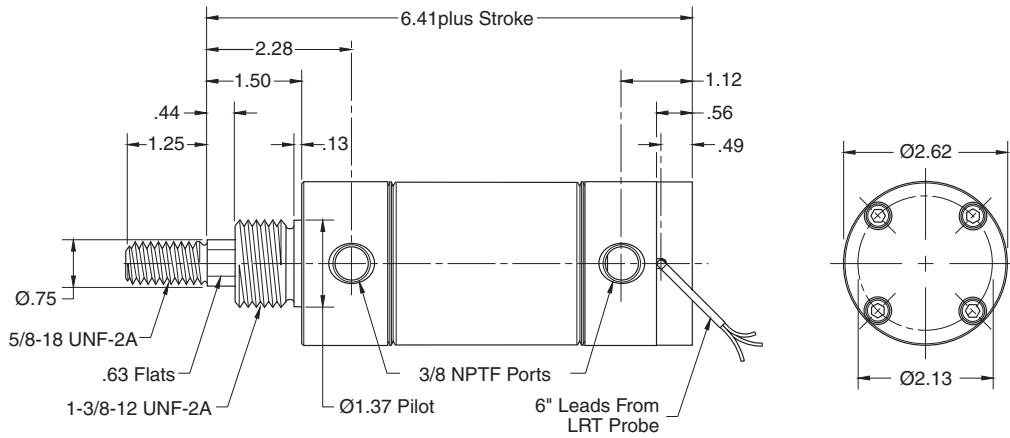

Style DXP

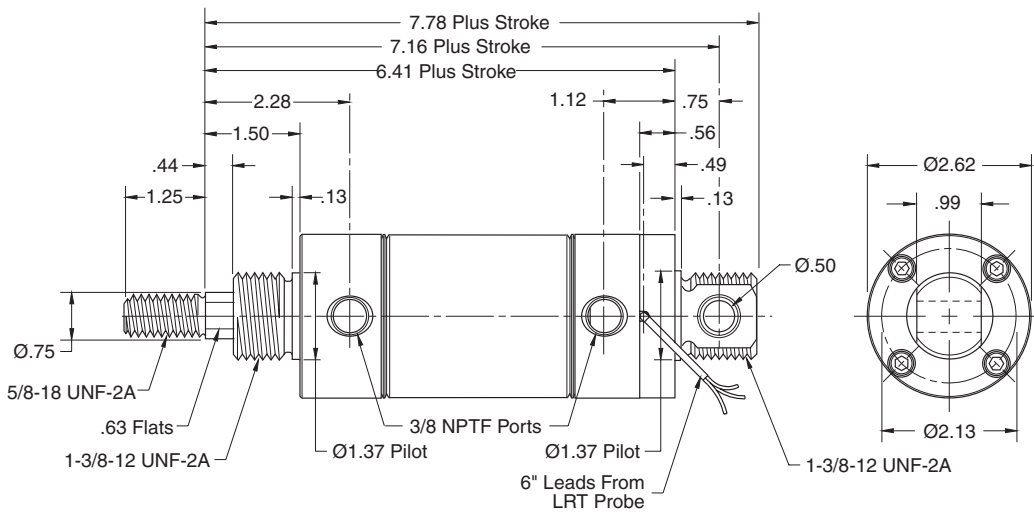

Style BFD

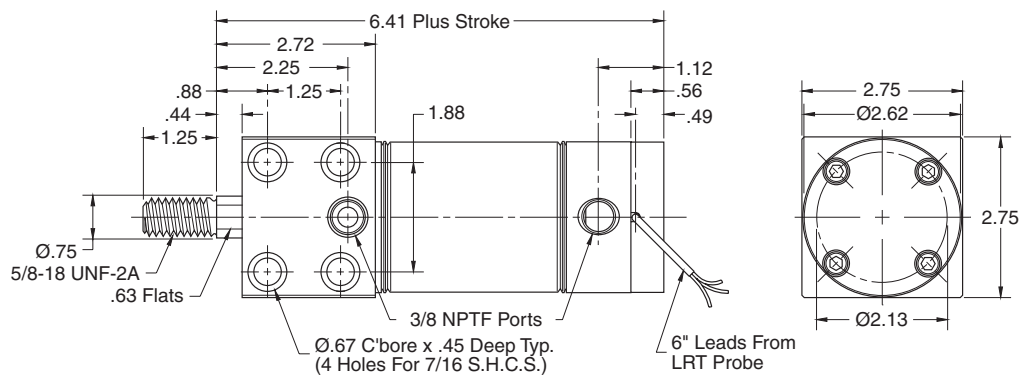

3" Bore Cylinders

Style D

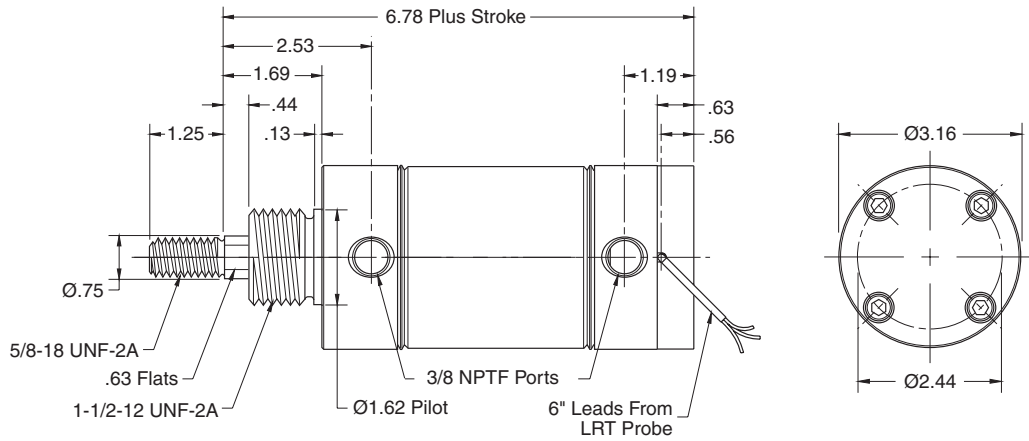

Style DXP

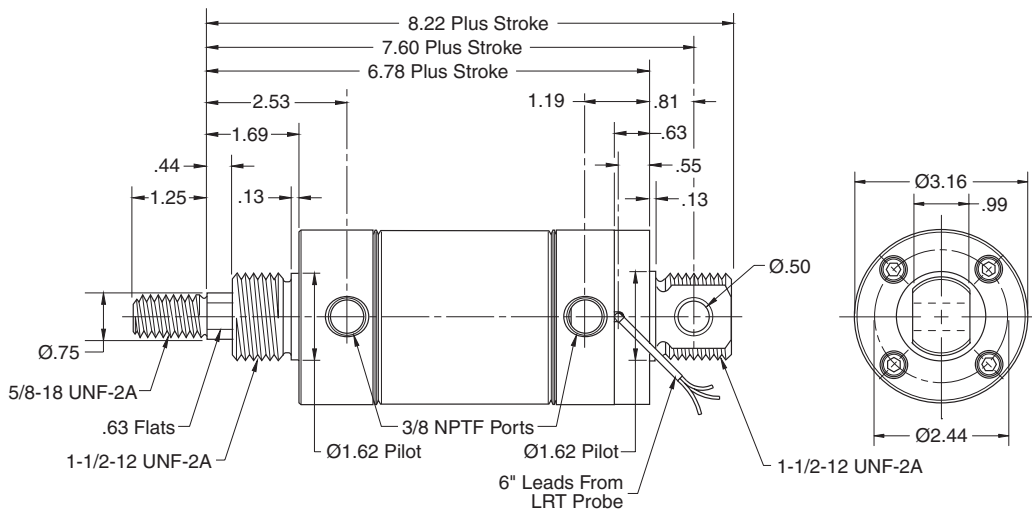

Style BFD

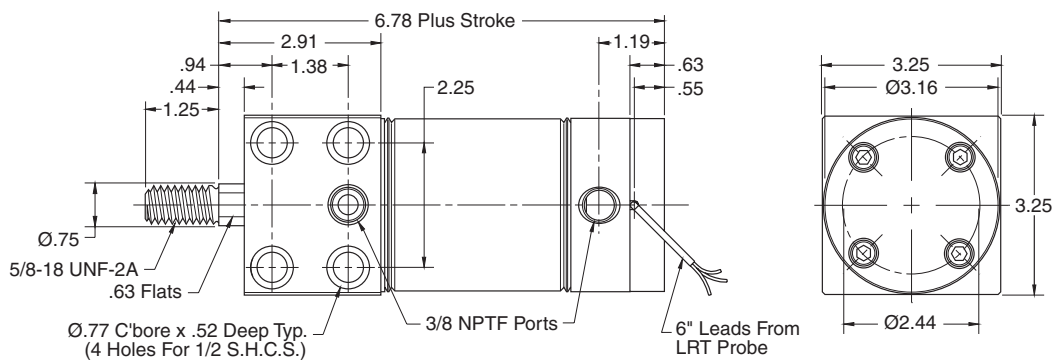

Piston Rod Clevis

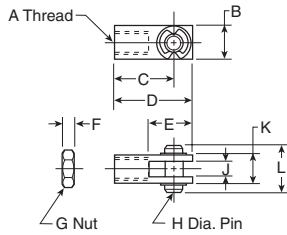

Bore size	A	B	C	D	E	F	G	H	J	K	L	Part number
1-1/16	3/8-24	.63	1.38	1.69	.94	.22	3/8-24	.31	.32	.63	.88	L071300350
1-1/2	7/16-20	.75	1.31	1.69	.94	.25	7/16-20	.38	.38	.75	1.03	L071300400
2	1/2-20	.88	1.88	2.31	1.31	.31	1/2-20	.44	.45	.88	1.14	L071300550
2-1/2, 3	5/8-18	1.00	2.25	2.75	1.50	.38	5/8-18	.50	.51	1.00	1.38	L071300600

Pivot Brackets

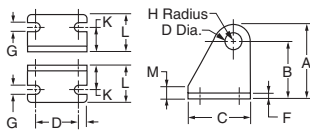

Bore size	A	B	C	D	E	F	G	H	J	K	L	M	Part number
1-1/16	1.31	1.00	1.31	.81	.25	.16	.28	.31	.315	.56	.88	.28	L071310400
1-1/2	1.63	1.25	1.63	1.00	.31	.19	.34	.38	.378	.69	1.13	.31	L071310500
2	1.81	1.38	1.81	1.19	.31	.25	.34	.44	.440	.75	1.19	.38	L071310600
2-1/2, 3	2.13	1.63	2.13	1.38	.38	.25	.41	.50	.503	.88	1.38	.38	L071310700

Pivot Brackets

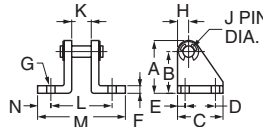

Bore size	A	B	C	D	E	F	G	H	J	K	L	M	N	Part number
1-1/16	1.31	1.00	1.31	.81	.25	.16	.28	.31	.312	.62	1.75	2.38	.31	L071320250
1-1/2	1.63	1.25	1.63	1.00	.31	.19	.34	.38	.375	.75	2.13	3.00	.44	L071320350
2	1.81	1.38	1.81	1.19	.31	.25	.34	.44	.437	.88	2.38	3.25	.44	L071320450
2-1/2, 3	2.13	1.63	2.13	1.38	.38	.25	.41	.50	.500	1.00	2.75	3.75	.50	L071320550

Foot Brackets

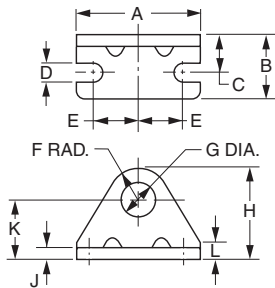

Bore size	A	B	C	D	E	F	G	H	J	K	L	Part number
1-1/16	2.13	1.16	.66	.28	.75	.75	.88	1.75	.16	1.00	.38	L073790056
1-1/2	2.75	1.44	.81	.35	1.00	.94	1.13	2.19	.19	1.25	.38	L073790108
2	3.00	1.59	.91	.35	1.19	1.06	1.26	2.44	.22	1.38	.44	L073790116
2-1/2	3.75	1.88	1.06	.41	1.50	1.19	1.38	2.81	.25	1.63	.50	L073790125
3	4.38	1.62	1.00	.35	1.75	1.25	1.64	3.14	.25	1.89	.89	L073790140

Mounting Nut

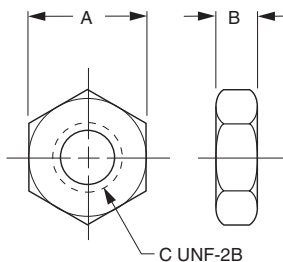

Bore size	A	B	C	Part number
1-1/16	1.31	.48	7/8-14	L073801000
1-1/2	1.69	.61	1-1/8-12	L073801300
2	1.88	.50	1-1/4-12	L073801200
2-1/2	2.06	.78	1-3/8-12	L073801400
3	2.25	.84	1-1/2-12	L073801500

Most popular.



SRG/SRGM Series

- 304 stainless steel cylinder body, non repairable construction
- 303 Stainless steel heads and caps
- 303 Stainless steel piston rod standard on all bore sizes
- Urethane rod wiper standard
- Available with bumpers and magnetic pistons
- Double acting models only
- Available with Nose, Foot and Pivot Mounts
- Corrosion resistant, reinforced plastic pivot bushing



Operating information

Operating pressure: 250 PSIG (17 bar) for SRG and SRGM
 Temperature range: -10°F to 165°F (-23°C to 74°C) for SRG
 14°F to 140°F (-10°C to 60°C) for SRGM
 Filtration requirements: 40 micron, dry filtered air

Ordering information

1.06	D	SRG	B	V	Y	2.00
Bore Size	Mounting	Series	Piston	Seals	Non-Standard Rod	Stroke
.75 3/4"	D, DXP	SRG Stainless caps	Blank No bumpers	Blank Standard seals	Y Stainless steel piston rod 303 stainless steel is standard on all bore sizes	Specify in inches
1.06 1-1/16"		SRGM Stainless caps and magnetic piston	B With bumpers	V Fluorocarbon seals*	Non-Standard Piston Rod Use "3" only when special piston rod end is required. Specify CC, LE and A Dimensions (See below.)	
1.50 1-1/2"				Urethane rod wiper is standard * Fluorocarbon seals not available on SRGM series.		
2.00 2"						
2.50 2-1/2"						
				Special		
				Use "S" only if special modifications are required, except piston rod end.		

Sensors
For sensors see page 39-42.

Non-Standard Rods

For non-standard rod dimensions, or undersized rod end threads, put a "3" in model number and describe the rod using the letters shown in the drawing. Specify CC, LE and A dimensions. LE is measured in retracted position.

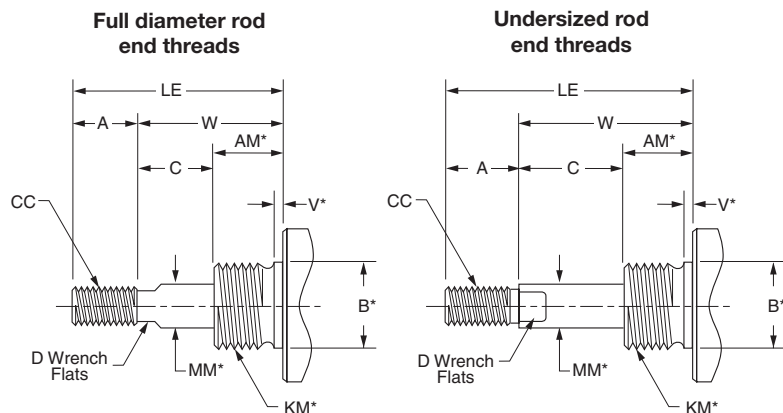

* Requires an S designation in model number.

Mounting Style D

Nose mount, double acting

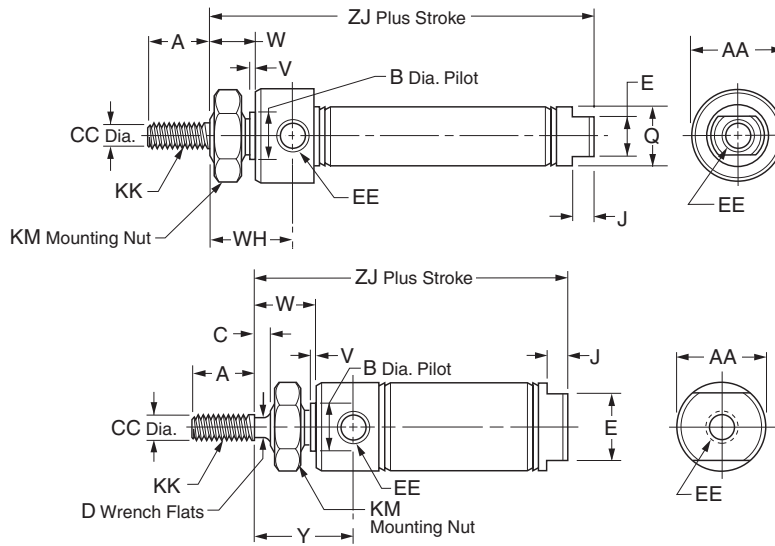

Bore sizes
3/4"

Bore sizes
1-1/16"
1-1/2"
2" *
2-1/2" *
* No mounting nuts

Bore size	Std. stroke (in)	Max. stroke (in)	SS rod std	A	AA	B	C	CC	D
3/4"	1/2, 1, 2, 2-1/2, 3, 4, 5, 6, 8, 10	12	✓	0.50	0.86	0.624	-	0.250	-
1-1/16"	1/2, 1, 1-1/2, 2, 2-1/2, 3, 4, 5, 6, 8, 10, 12	12	✓	0.50	1.12	0.624	0.12	0.312	0.25
1-1/2"	1/2, 1, 2, 3, 4, 5, 6, 8, 10, 12	12	✓	0.75	1.56	0.749	0.25	0.437	0.38
2"	-	12	✓	0.88	2.08	1.374	0.38	0.625	0.50
2-1/2"	-	12	✓	0.88	2.62	1.500	0.38	0.625	1/2

Bore size											ZJ	
	E	EE	J	KK	KM	Q	V	W	WH	Y	SRG	SRGM
3/4"	0.62	1/8 NPTF	0.19	1/4-28 UNF	5/8-18	0.81	0.09	0.50	0.97	-	2.97	2.97
1-1/16"	0.88	1/8 NPTF	0.19	5/16-24 UNF	5/8-18	-	0.09	0.62	-	1.19	3.25	3.41
1-1/2"	0.88	1/8 NPTF	0.25	7/16-20 UNF	3/4-16	-	0.09	0.88	-	1.50	3.69	3.94
2"	1.25	1/4 NPTF	0.31	1/2-20 UNF	1-1/4-12	-	0.12	1.19	-	1.84	4.69	4.97
2-1/2"	1.75	1/4 NPTF	0.31	1/2-20 UNF	1-3/8-12	-	0.13	1.19	-	1.84	4.69	4.69

Mounting nuts sold separately for all series SRG

Mounting Style DXP

Pivot & nose mount, double acting, no pivot pin

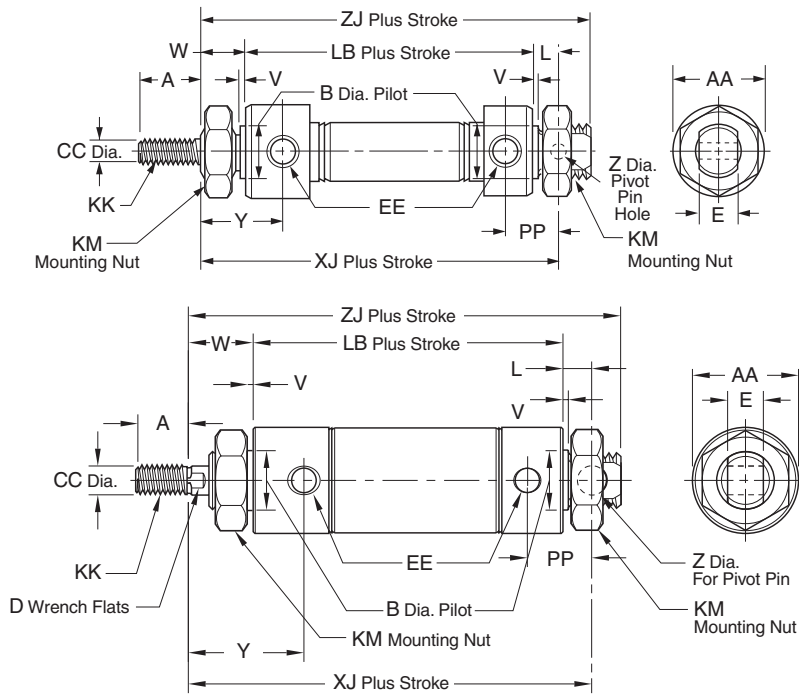

Bore sizes
3/4"

Bore sizes
1-1/16"
1-1/2"
2" *
2-1/2" *

* No mounting nuts

Bore size	Std. stroke (in)	Max. stroke (in)	SS rod std	A	AA	B	CC	D	E	EE
3/4"	1, 2, 3, 4, 5, 6, 8, 10	32	✓	0.50	0.86	0.624	0.250	-	0.38	1/8 NPTF
1-1/16"	1/2, 1, 1-1/2, 2, 2-1/2, 3, 4, 5, 6, 8, 10, 12	32	✓	0.50	1.12	0.624	0.312	0.25	0.38	1/8 NPTF
1-1/2"	-	32	✓	0.75	1.56	0.749	0.437	0.38	0.62	1/8 NPTF
2"	-	32	✓	0.88	2.08	1.374	0.625	0.50	0.75	1/4 NPTF
2-1/2"	-	32	✓	0.88	2.62	1.500	0.625	1/2	0.75	1/4 NPTF

Bore size	KK	KM	L	LB	PP	V	W	XJ		Y	Z	ZJ	
								SRG	SRGM			SRG	SRGM
3/4"	1/4-28 UNF	5/8-18	0.34	2.91	0.62	0.09	0.50	3.75	3.75	0.97	0.251	4.03	4.03
1-1/16"	5/16-24 UNF	5/8-18	0.34	-	0.62	0.09	0.62	3.84	-	1.19	0.251	4.12	4.28
1-1/2"	7/16-20 UNF	3/4-16	0.50	-	0.81	0.09	0.88	4.38	4.63	1.50	0.376	4.75	5.00
2"	1/2-20 UNF	1-1/4-12	0.56	-	1.03	0.12	1.19	5.62	5.91	-	0.376	6.06	6.34
2-1/2"	1/2-20 UNF	1-3/8-12	0.56	-	1.03	0.13	1.19	5.62	5.62	1.84	0.376	6.06	6.06

Mounting nuts sold separately for all series SRG

Piston Rod Clevis

Assembly includes pin and (2) retainer rings and (1) jam nut.

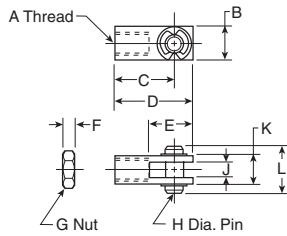

Bore size	A	B	C	D	E	F	G	H	J	K	L	Part number
3/4	1/4-28	.50	.94	1.19	.68	.16	1/4-28	.25	.25	.50	.69	L077130200
1-1/16	5/16-24	.50	.94	1.19	.68	.19	5/16-24	.25	.25	.50	.69	L077130300
1-1/2	7/16-20	.75	1.31	1.69	.94	.25	7/16-20	.38	.38	.75	1.03	L077130400
2, 2-1/2	1/2-20	.75	1.31	1.69	.94	.31	1/2-20	.38	.38	.75	1.03	L077130500

Pivot Bracket Assembly

Assembly includes pin and (2) retainer rings.

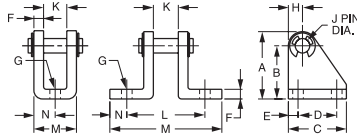

Bore size	A	B	C	D	E	F	G	H	J	K	L	M	N	Part number
3/4, 1-1/16	1.18	.88	1.12	.75	.19	.12	.27	.30	.250	.38	1.25	2.00	.38	L077150200
1-1/2	1.75	1.38	1.50	1.00	.25	.25	.27	.37	.375	.62	2.00	2.88	.44	L077150400
2, 2-1/2	1.75	1.38	1.50	1.00	.25	.25	.27	.37	.375	.75	2.12	3.00	.44	L077150500

Stainless steel.

Foot Brackets

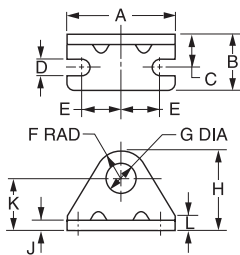

Bore size	A	B	C	D	E	F	G	H	J	K	L	Part number
3/4, 1-1/16	1.88	1.00	.56	.27	.75	.56	.63	1.38	.12	.81	.25	L077160040
1-1/2	2.50	1.50	.75	.27	.94	.75	.75	1.75	.12	1.00	.38	L077160048
2	3.12	1.62	1.00	.34	1.12	1.00	1.38	2.50	.25	1.50	.62	L077160124
2-1/2	3.75	1.62	1.00	.35	1.44	1.25	1.51	3.00	.25	1.75	.75	L077160132

Stainless steel.

Mounting Nut

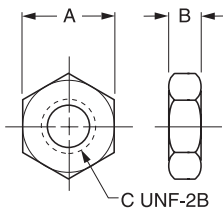

Bore size	A	B	C	Part number
3/4, 1-1/16	.94	.38	5/8-18	L077170800
1-1/2	1.12	.42	3/4-16	L077170900
2	1.88	.50	1-1/4-12	L077171200
2-1/2	2.06	.78	1-3/8-12	L077171400

Stainless steel.

Electronic Sensor Selection Guide

PNP Solid State Sensor

Bore size or type	3m flying leads	10m flying leads	8mm quick connect	8mm quick connect w/ 1 m lead	12mm quick connect	Bracket	Sensor page #	Bracket page #
9/16" - 3/4"	P8S-GPFLX	P8S-GPFTX	P8S-GPSHX	P8S-GPSCX	P8S-GPMHX	P8S-TMC01	40	42
1-1/16" - 2-1/2"	P8S-GPFLX	P8S-GPFTX	P8S-GPSHX	P8S-GPSCX	P8S-GPMHX	P8S-TMC02	40	42

NPN Solid State Sensor

Bore size or type	3m flying leads	10m flying leads	8mm quick connect	8mm quick connect w/ 1m lead	12mm quick connect	Bracket	Sensor page #	Bracket page #
9/16" - 3/4"	P8S-GNFLX	P8S-GNFTX	P8S-GNSHX	P8S-GNSCX	P8S-GNMHX	P8S-TMC01	40	42
1-1/16" - 2-1/2"	P8S-GNFLX	P8S-GNFTX	P8S-GNSHX	P8S-GNSCX	P8S-GNMHX	P8S-TMC02	40	42

Reed Sensor

Bore size or type	3m flying leads	10m flying leads	8mm quick connect	8mm quick connect w/ 1m lead	12mm quick connect	Bracket	Sensor page #	Bracket page #
9/16" - 3/4"	P8S-GRFLX	P8S-GRFTX	P8S-GRSHX	P8S-GRSCX	P8S-GRMHX	P8S-TMC01	41	42
1-1/16" - 2-1/2"	P8S-GRFLX	P8S-GRFTX	P8S-GRSHX	P8S-GRSCX	P8S-GRMHX	P8S-TMC02	41	42

1. Flying leads are 2 meters in length
2. Flying leads are 1.5 meters in length
3. Flying leads are 1 meter in length
4. Flying leads are 5 meter in length

P8S Global Drop-In Solid State Sensors



Wiring	PNP sensor	NPN sensor	PNP sensor ATEX certified
3m flying leads	P8S-GPFLX	P8S-GNFLX	P8S-GPFLX/EX
10m flying leads	P8S-GPFTX	P8S-GNFTX	
0.3m lead with 8mm connector	P8S-GPSHX	P8S-GNSHX	N/A
0.3m lead with 12mm connector	P8S-GPMHX	P8S-GNMHX	
1m lead with 8mm connector	P8S-GPSCX	P8S-GNSCX	

Specifications

Switch classification	Standard PNP or NPN	ATEX certified PNP
Type	Electronic	
Output function	Normally open	
Sensor output	PNP/NPN	PNP
Operating voltage	10 - 30VDC	180 - 30VDC
Continuous current	100 mA max.	70 mA max.
Response sensitivity	28 Gauss min.	
Switching frequency	1 KHz	
Power consumption	10 mA max.	
Voltage drop	2.5 VDC max.	
Ripple	10% of operating voltage	
Hysteresis	1.5 mm max.	
Repeatability	0.1 mm max.	
EMC	EN 60 947-5-2	
Short-circuit protection	Yes	
Power-up pulse suppression	Yes	
Reverse polarity protection	Yes	
Enclosure rating	IP 68	
Shock and vibration stress	30g, 11 ms, 10 to 55 Hz, 1 mm	
Operating temperature range	-25°C to +75°C (-13°F to 167°F)	-20°C to +45°C (-4°F to 113°F)
Housing material	PA 12, black	
Connector cable	PVC	
Connector	PUR	—
Approval for ATEX	—	3D/3G

Wiring connection

Flying lead or 8 mm connector (shown)

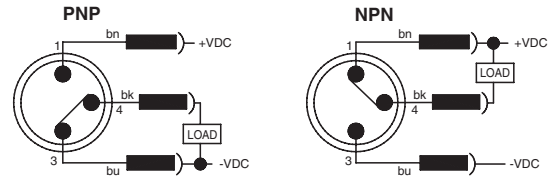
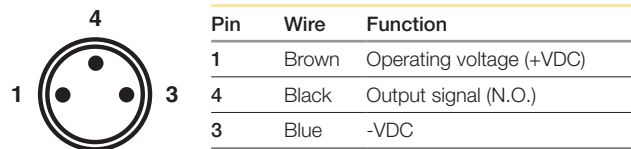

12 mm connector

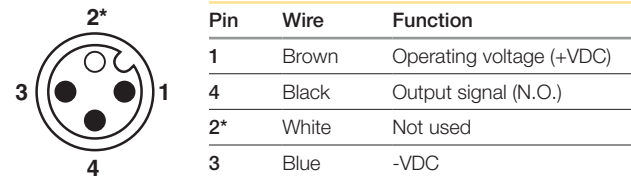

* Pin 2 not present.

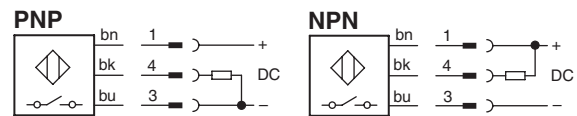

Dimensions

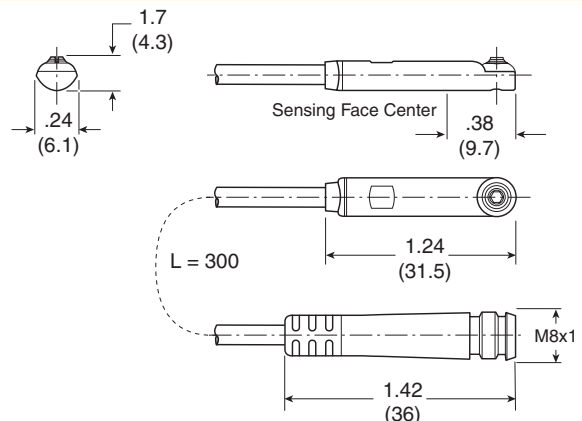

P8S Global Drop-In Reed Sensors



Wiring	Reed sensor
3m flying leads	P8S-GRFLX
10m flying leads	P8S-GRFTX
0.3m lead with 8mm connector	P8S-GRSHX
0.3m lead with 12mm connector	P8S-GRMHX
1m lead with 8mm connector	P8S-GRSCX

Specifications

Type	2-Wire Reed
Output function	Normally open
Operating voltage	10 - 120 VAC*, 10 - 30 VDC
Switching power	6 W/VA
Continuous current	100 mA max.
Response sensitivity	30 Gauss min.
Switching frequency	400 Hz
Voltage drop	2.5 V max.
Ripple	10% of operating voltage
Hysteresis	1.5 mm max.
Repeatability	0.2 mm max.
Emc	EN 60 947-5-2
Reverse polarity protection	Yes
Enclosure rating	IP 68
Shock and vibration stress	30g, 11 ms, 10 to 55 Hz, 1 mm
Operating temperature range	-25°C to 75°C (-13°F to 167°F)
Housing material	PA 12, Black
Connector cable	PVC
Connector	PUR cable with 8 or 12 mm connector

* 8mm connector rated for 50 vac max.

Circuit for switching contact protection (for inductive loads, e.g. solenoids, relays)

(Required for proper operation 24VDC)

Put diode parallel to load (CR) following polarity as shown.

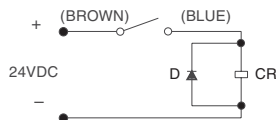

D: Diode: select a diode with the breakdown voltage and current rating according to the load.

Typical Example – 100 volt, 1 amp diode
 CR: Relay coil (under 0.5W coil rating)

(Recommended for longer life 120 VAC)

Put a resistor and capacitor in parallel with the load (CR).
 Select the resistor and capacitor according to the load.

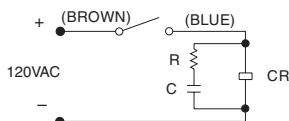

Typical Example:

CR: Relay coil (under 2W coil rating)
 R: Resistor 1 KΩ - 5 KΩ, 1/4 W
 C: Capacitor 0.1 μF, 600 V

Wiring connection

Flying Lead or 8 mm Connector

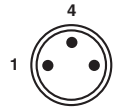

Pin	Wire	Function
1	Brown	Operating voltage (+V)
4	Black	Not used
3	Blue	Output signal (-V or ground)

12 mm Connector

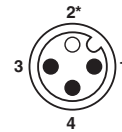

Pin	Wire	Function
1	Brown	Operating voltage (+V)
2*	White	Not used
3	Blue	Output signal (-V or ground)
4	Black	Not used

* Pin 2 not present.

Dimensions

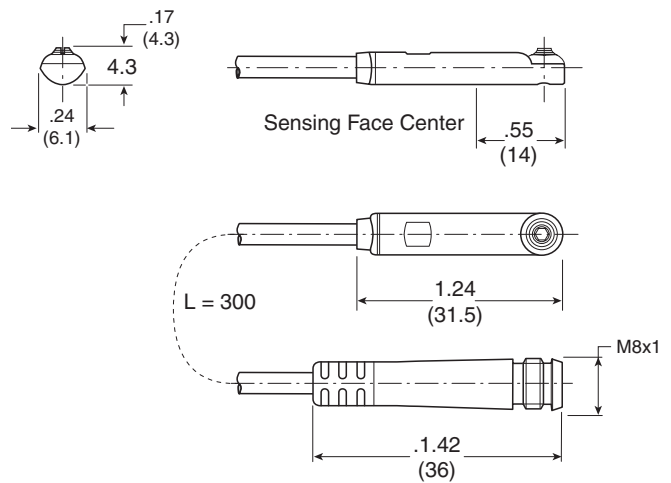

⚠ Caution

- Use an ammeter to test reed sensor current. Testing devices such as incandescent light bulbs may subject the reed sensor to high in-rush loads.
- **NOTE:** When checking an unpowered reed sensor for continuity with a digital ohmmeter the resistance reading will change from infinity to a very large resistance (2 M ohm) when the sensor is activated. This is due to the presence of a diode in the reed sensor.
- Anti-magnetic shielding is recommended for reed sensors exposed to high external RF or magnetic fields.
- The magnetic field strength of the piston magnet is designed to operate with our sensors. Other manufacturers' sensors may not operate correctly in conjunction with these magnets.
- Use relay coils for reed sensor contact protection.
- The operation of some 120 VAC PLC's (especially some older Allen-Bradley PLC's) can overload the reed sensor. The sensor may fail to release after the piston magnet has passed. This problem may be corrected by the placement of a 700 to 1K OHM resistor between the sensor and the PLC input terminal. Consult the manufacturer of the PLC for appropriate circuit.
- Sensors with long wire leads (greater than 15 feet) can cause capacitance build-up and sticking will result. Attach a resistor in series with the reed sensor (the resistor should be installed as close as possible to the sensor). The resistor should be selected such that R (ohms) > E/0.3.

Round body bracket assembly part numbers

Sensors and brackets must be ordered separately

Bore size	Round body bracket
9/16" - 1-1/16"	P8S-TMC01
20 - 25mm	P8S-TMC01
1-1/8" - 2-1/2"	P8S-TMC02
32 - 63mm	P8S-TMC02
3" - 4"	P8S-TMC03
80 - 100mm	P8S-TMC03

P8S-TMA0Z

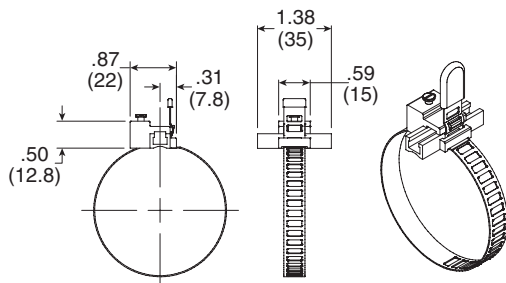

Parker Safety Guide for Selecting and Using Hydraulic, Pneumatic Cylinders and Their Accessories

WARNING: ⚠ FAILURE OR IMPROPER SELECTION OR IMPROPER USE OF CYLINDERS AND THEIR RELATED ACCESSORIES CAN CAUSE DEATH, PERSONAL INJURY AND PROPERTY DAMAGE.

Before selecting or using Parker cylinders or related accessories, it is important that you read, understand and follow the following safety information.

User Responsibility

Due to very wide variety of cylinder applications and cylinder operating conditions, Parker does not warrant that any particular cylinder is suitable for any specific application. This safety guide does not analyze all technical parameters that must be considered in selecting a product. The hydraulic and pneumatic cylinders outlined in this catalog are designed to Parker's design guide lines and do not necessarily meet the design guide lines of other agencies such as American Bureau of Shipping, ASME Pressure Vessel Code etc. The user, through its own analysis and testing, is solely responsible for:

- Making the final selection of the cylinders and related accessories.
- Determining if the cylinders are required to meet specific design requirements as required by the Agency(s) or industry standards covering the design of the user's equipment.
- Assuring that the user's requirements are met, OSHA requirements are met, and safety guidelines from the applicable agencies such as but not limited to ANSI are followed and that the use presents no health or safety hazards.
- Providing all appropriate health and safety warnings on the equipment on which the cylinders are used.

Seals

Part of the process of selecting a cylinder is the selection of seal compounds. Before making this selection read the Operating Fluids and Seals section in this catalog or in the Application Engineering Data section of the current 0106 or 0900P series catalogs, or contact our engineering department.

The application of cylinders may allow fluids such as cutting fluids, wash down fluids etc. to come in contact with the external area of the cylinder. These fluids may attack the piston rod wiper and or the primary seal and must be taken into account when selecting and specifying seal compounds.

Dynamic seals will wear. The rate of wear will depend on many operating factors. Wear can be rapid if a cylinder is mis-aligned or if the cylinder has been improperly serviced. The user must take seal wear into consideration in the application of cylinders.

Piston Rods

Possible consequences of piston rod failure or separation of the piston rod from the piston include, but are not limited to are:

- Piston rod and or attached load thrown off at high speed.
- High velocity fluid discharge.
- Piston rod extending when pressure is applied in the piston retract mode.

Piston rods or machine members attached to the piston rod may move suddenly and without warning as a consequence of other conditions occurring to the machine such as, but not limited to:

- Unexpected detachment of the machine member from the piston rod.
- Failure of the pressurized fluid delivery system (hoses, fittings, valves, pumps, compressors) which maintain cylinder position.
- Catastrophic cylinder seal failure leading to sudden loss of pressurized fluid.
- Failure of the machine control system.

Following the recommendation of the cylinder stroke chart found in this catalog or in the Cylinder Application Engineering Data section of the current 0106 or 0900P series catalogs. The suggested piston rod diameter in these charts must be followed in order to avoid piston rod buckling.

Piston rods are not normally designed to absorb bending moments or loads which are perpendicular to the axis of piston rod motion. These additional loads can cause the piston rod to fail. If these types of additional loads are expected to be imposed on the piston rod, their magnitude should be made known to our engineering department.

The cylinder user should always make sure that the piston rod is securely attached to the machine member.

On occasion cylinders are ordered with double rods (a piston rod extended from both ends of the cylinder). In some cases a stop is threaded on to one of the piston rods and used as an external stroke adjuster. On occasions spacers are attached to the machine member connected to the piston rod and also used as a stroke adjuster. In both cases the stops will create a pinch point and the user should consider appropriate use of guards. If these external stops are not perpendicular to the mating contact surface, or if debris is trapped between the contact surfaces, a bending moment will be placed on the piston rod, which can lead to piston rod failure. An external stop will also negate the effect of cushioning and will subject the piston rod to impact loading. Those two (2) conditions can cause piston rod failure. Internal stroke adjusters are available with and without cushions. The use of external stroke adjusters should be reviewed with our engineering department.

The piston rod to piston and the stud to piston rod threaded connections are secured with an anaerobic adhesive. The strength of the adhesive decreases with increasing temperature. Cylinder which can be exposed to temperatures above +250°F (+121°C) are to be ordered with a non studded piston rod and a pinned piston to rod joint.

Cushions

Cushions should be considered for cylinder applications when the piston velocity is expected to be over 4 inches/second. Cylinder cushions are normally designed to absorb the energy of a linear applied load. A rotating mass has considerably more energy than the same mass moving in a linear mode. Cushioning for a rotating mass application should be reviewed by our engineering department.

Cylinder Mountings

Some cylinder mounting configurations may have certain limitations such as but not limited to minimum stroke for side or foot mounting cylinders or pressure de-ratings for certain flange mounts. Carefully review the catalog for these types of restrictions.

Always mount cylinders using the largest possible high tensile alloy steel socket head cap screws that can fit in the cylinder mounting holes and torque them to the manufacturer's recommendations for their size.

Port Fittings

Hydraulic cylinders applied with meter out or deceleration circuits are subject to intensified pressure at piston rod end. The rod end pressure is approximately equal to:

$$\frac{\text{operating pressure} \times \text{effective cap end area}}{\text{effective rod end piston area}}$$

Contact your connector supplier for the pressure rating of individual connectors.

Cylinder Modifications or Repairs

Cylinders as shipped from the factory are not to be disassembled and or modified. If cylinders require modifications, these modifications must be done at Parker locations or by Parker certified facilities. It is allowed to disassemble cylinders for the purpose of replacing seals or seal assemblies. However, this work must be done by strictly following all the instructions provided with the seal kits.

The goods, services or work (referred to as the "Products") offered by **Parker-Hannifin Corporation**, its subsidiaries, groups, divisions, and authorized distributors ("Seller") are offered for sale at prices indicated in the offer, or as may be established by Seller. The offer to sell the Products and acceptance of Seller's offer by any customer ("Buyer") is contingent upon, and will be governed by all of the terms and conditions contained in this Offer of Sale. Buyer's order for any Products specified in Buyer's purchase document or Seller's offer, proposal or quote ("Quote") attached to the purchase order, when communicated to Seller verbally, or in writing, shall constitute acceptance of this offer.

1. Terms and Conditions. Seller's willingness to offer Products for sale or accept an order for Products is subject to the terms and conditions contained in this Offer of Sale or any newer version of the same, published by Seller electronically at www.parker.com/saleterms/. Seller objects to any contrary or additional terms or conditions of Buyer's order or any other document or other communication issued by Buyer.

2. Price; Payment. Prices stated on Seller's Quote are valid for thirty (30) days, except as explicitly otherwise stated therein, and do not include any sales, use, or other taxes or duties unless specifically stated. Seller reserves the right to modify prices to adjust for any raw material price fluctuations. Unless otherwise specified by Seller, all prices are F.C.A. Seller's facility (INCOTERMS 2010). Payment is subject to credit approval and payment for all purchases is due thirty (30) days from the date of invoice (or such date as may be specified by Seller's Credit Department). Unpaid invoices beyond the specified payment date incur interest at the rate of 1.5% per month or the maximum allowable rate under applicable law.

3. Shipment; Delivery; Title and Risk of Loss. All delivery dates are approximate. Seller is not responsible for damages resulting from any delay. Regardless of the manner of shipment, delivery occurs and title and risk of loss or damage pass to Buyer, upon placement of the Products with the shipment carrier at Seller's facility. Unless otherwise stated, Seller may exercise its judgment in choosing the carrier and means of delivery. No deferral of shipment at Buyers' request beyond the respective dates indicated will be made except on terms that will indemnify, defend and hold Seller harmless against all loss and additional expense. Buyer shall be responsible for any additional shipping charges incurred by Seller due to Buyer's acts or omissions.

4. Warranty. Seller warrants that the Products sold hereunder shall be free from defects in material or workmanship for a period of twelve (12) months from the date of delivery or 2,000 hours of normal use, whichever occurs first. All prices are based upon the exclusive limited warranty stated above, and upon the following disclaimer: **DISCLAIMER OF WARRANTY: THIS WARRANTY IS THE SOLE AND ENTIRE WARRANTY PERTAINING TO PRODUCTS PROVIDED. SELLER DISCLAIMS ALL OTHER WARRANTIES, EXPRESS AND IMPLIED, INCLUDING DESIGN, MERCHANTABILITY AND FITNESS FOR A PARTICULAR PURPOSE.**

5. Claims; Commencement of Actions. Buyer shall promptly inspect all Products upon receipt. No claims for shortages will be allowed unless reported to the Seller within ten (10) days of delivery. No other claims against Seller will be allowed unless asserted in writing within thirty (30) days after delivery. Buyer shall notify Seller of any alleged breach of warranty within thirty (30) days after the date the defect is or should have been discovered by Buyer. Any claim or action against Seller based upon breach of contract or any other theory, including tort, negligence, or otherwise must be commenced within twelve (12) months from the date of the alleged breach or other alleged event, without regard to the date of discovery.

6. LIMITATION OF LIABILITY. IN THE EVENT OF A BREACH OF WARRANTY, SELLER WILL, AT ITS OPTION, REPAIR OR REPLACE A DEFECTIVE PRODUCT, OR REFUND THE PURCHASE PRICE WITHIN A REASONABLE PERIOD OF TIME. **IN NO EVENT IS SELLER LIABLE FOR ANY SPECIAL, INDIRECT, INCIDENTAL OR CONSEQUENTIAL DAMAGES ARISING OUT OF, OR AS THE RESULT OF, THE SALE, DELIVERY, NON-DELIVERY, SERVICING, USE OR LOSS OF USE OF THE PRODUCTS OR ANY PART THEREOF, OR FOR ANY CHARGES OR EXPENSES OF ANY NATURE INCURRED WITHOUT SELLER'S WRITTEN CONSENT, WHETHER BASED IN CONTRACT, TORT OR OTHER LEGAL THEORY. IN NO EVENT SHALL SELLER'S LIABILITY UNDER ANY CLAIM MADE BY BUYER EXCEED THE PURCHASE PRICE OF THE PRODUCTS.**

7. User Responsibility. The user, through its own analysis and testing, is solely responsible for making the final selection of the system and Product and assuring that all performance, endurance, maintenance, safety and warning requirements of the application are met. The user must analyze all aspects of the application and follow applicable industry standards and Product information. If Seller provides Product or system options based upon data or specifications provided by the user, the user is responsible for determining that such data and specifications are suitable and sufficient for all applications and reasonably foreseeable uses of the Products or systems.

8. Loss to Buyer's Property. Any designs, tools, patterns, materials, drawings, confidential information or equipment furnished by Buyer or any other items which become Buyer's property, will be considered obsolete and may be destroyed by Seller after two (2) consecutive years have elapsed without Buyer ordering the items manufactured using such property. Seller shall not be responsible for any loss or damage to such property while it is in Seller's possession or control.

9. Special Tooling. A tooling charge may be imposed for any special tooling, including without limitation, dies, fixtures, molds and patterns, acquired to manufacture Products. Such special tooling shall be and remain Seller's property notwithstanding payment of any charges by Buyer. In no event will Buyer acquire any interest in apparatus belonging to Seller which is utilized in the manufacture of the Products, even if such apparatus has been specially converted or adapted for such manufacture and notwithstanding any charges paid by Buyer. Unless otherwise agreed, Seller has the right to alter, discard or otherwise dispose of any special tooling or other property in its sole discretion at any time.

10. Buyer's Obligation; Rights of Seller. To secure payment of all sums due or otherwise, Seller retains a security interest in all Products delivered to Buyer and this agreement is deemed to be a Security Agreement under the Uniform Commercial Code. Buyer authorizes Seller as its attorney to execute and file on Buyer's behalf all documents Seller deems necessary to perfect its security interest.

11. Improper Use and Indemnity. Buyer shall indemnify, defend, and hold Seller harmless from any losses, claims, liabilities, damages, lawsuits, judgments and costs

(including attorney fees and defense costs), whether for personal injury, property damage, patent, trademark or copyright infringement or any other claim, brought by or incurred by Buyer, Buyer's employees, or any other person, arising out of: (a) improper selection, application, design, specification or other misuse of Products purchased by Buyer from Seller; (b) any act or omission, negligent or otherwise, of Buyer; (c) Seller's use of patterns, plans, drawings, or specifications furnished by Buyer to manufacture Products; or (d) Buyer's failure to comply with these terms and conditions. Seller shall not indemnify Buyer under any circumstance except as otherwise provided.

12. Cancellations and Changes. Buyer may not cancel or modify or cancel any order for any reason, except with Seller's written consent and upon terms that will indemnify, defend and hold Seller harmless against all direct, incidental and consequential loss or damage. Seller may change Product features, specifications, designs and availability.

13. Limitation on Assignment. Buyer may not assign its rights or obligations under this agreement without the prior written consent of Seller.

14. Force Majeure. Seller does not assume the risk and is not liable for delay or failure to perform any of Seller's obligations by reason of events or circumstances beyond its reasonable control (hereinafter "Events of Force Majeure"). Events of Force Majeure shall include without limitation: accidents, strikes or labor disputes, acts of any government or government agency, acts of nature, delays or failures in delivery from carriers or suppliers, shortages of materials, or any other cause beyond Seller's reasonable control.

15. Waiver and Severability. Failure to enforce any provision of this agreement will not invalidate that provision; nor will any such failure prejudice Seller's right to enforce that provision in the future. Invalidation of any provision of this agreement by legislation or other rule of law shall not invalidate any other provision herein. The remaining provisions of this agreement will remain in full force and effect.

16. Termination. Seller may terminate this agreement for any reason and at any time by giving Buyer thirty (30) days prior written notice. Seller may immediately terminate this agreement, in writing, if Buyer: (a) breaches any provision of this agreement (b) appoints a trustee, receiver or custodian for all or any part of Buyer's property (c) files a petition for relief in bankruptcy on its own behalf, or one if filed by a third party (d) makes an assignment for the benefit of creditors; or (e) dissolves its business or liquidates all or a majority of its assets.

17. Governing Law. This agreement and the sale and delivery of all Products are deemed to have taken place in, and shall be governed and construed in accordance with, the laws of the State of Ohio, as applicable to contracts executed and wholly performed therein and without regard to conflicts of laws principles. Buyer irrevocably agrees and consents to the exclusive jurisdiction and venue of the courts of Cuyahoga County, Ohio with respect to any dispute, controversy or claim arising out of or relating to this agreement.

18. Indemnity for Infringement of Intellectual Property Rights. Seller is not liable for infringement of any patents, trademarks, copyrights, trade dress, trade secrets or similar rights except as provided in this Section. Seller will defend and indemnify Buyer against allegations of infringement of U.S. patents, U.S. trademarks, copyrights, trade dress and trade secrets ("Intellectual Property Rights"). Seller will defend at its expense and will pay the cost of any settlement or damages awarded in an action brought against Buyer based on an allegation that a Product sold pursuant to this agreement infringes the Intellectual Property Rights of a third party. Seller's obligation to defend and indemnify Buyer is contingent on Buyer notifying Seller within ten (10) days after Buyer becomes aware of such allegations of infringement, and Seller having sole control over the defense of any allegations or actions including all negotiations for settlement or compromise. If a Product is subject to a claim that it infringes the Intellectual Property Rights of a third party, Seller may, at its sole expense and option, procure for Buyer the right to continue using the Product, replace or modify the Product so as to make it noninfringing, or offer to accept return of the Product and refund the purchase price less a reasonable allowance for depreciation. Notwithstanding the foregoing, Seller is not liable for claims of infringement based on information provided by Buyer, or directed to Products delivered hereunder for which the designs are specified in whole or part by Buyer, or infringements resulting from the modification, combination or use in a system of any Product sold hereunder. The foregoing provisions of this Section constitute Seller's sole and exclusive liability and Buyer's sole and exclusive remedy for infringement of Intellectual Property Rights.

19. Entire Agreement. This agreement contains the entire agreement between the Buyer and Seller and constitutes the final, complete and exclusive expression of the terms of sale. All prior or contemporaneous written or oral agreements or negotiations with respect to the subject matter are herein merged. The terms contained herein may not be modified unless in writing and signed by an authorized representative of Seller.

20. Compliance with Laws. Buyer agrees to comply with all applicable laws, regulations, and industry and professional standards of care, including those of the United Kingdom, the United States of America, and the country or countries in which Buyer may operate, including without limitation the U. K. Bribery Act, the U.S. Foreign Corrupt Practices Act ("FCPA"), the U.S. Anti-Kickback Act ("Anti-Kickback Act") and the U.S. Food Drug and Cosmetic Act ("FDCA"), each as currently amended, and the rules and regulations promulgated by the U.S. Food and Drug Administration ("FDA"), and agrees to indemnify and hold harmless Seller from the consequences of any violation of such provisions by Buyer, its employees or agents. Buyer acknowledges that it is familiar with the provisions of the U. K. Bribery Act, the FCPA, the FDA, and the Anti-Kickback Act, and certifies that Buyer will adhere to the requirements thereof. In particular, Buyer represents and agrees that Buyer will not make any payment or give anything of value, directly or indirectly to any governmental official, any foreign political party or official thereof, any candidate for foreign political office, or any commercial entity or person, for the purpose of influencing such person to purchase Products or otherwise benefit the business of Seller.

05/14





Parker Hannifin Corporation
Pneumatic Division
8676 E. M89
P.O. Box 901
Richland, MI 49083 USA
Tel: (269) 629-5000
Fax: (269) 629-5385

Applications Engineering

Phone: (269) 629-5575 Option #3
E-mail: pdnapps@parker.com

Customer Support

Phone: (269) 629-5575 Option #1
E-mail: pdncustsvc@parker.com
Web site: www.parker.com/pneumatics